

Service Manual

ViewSonic VA902-2 VA902b-2

Model No. VS10715

19" Color TFT LCD Display

(VA902-2_VA902b-2_SM Rev. 1a Jan. 2006)

ViewSonic® 381 Brea Canyon Road, Walnut, California 91789 USA - (800) 888-8583

Copyright

Copyright © 2005 by ViewSonic Corporation. All rights reserved. No part of this publication may be reproduced, transmitted, transcribed, stored in a retrieval system, or translated into any language or computer language, in any form or by any means, electronic, mechanical, magnetic, optical, chemical, manual or otherwise, without the prior written permission of ViewSonic Corporation.

Disclaimer

ViewSonic makes no representations or warranties, either expressed or implied, with respect to the contents hereof and specifically disclaims any warranty of merchantability or fitness for any particular purpose. Further, ViewSonic reserves the right to revise this publication and to make changes from time to time in the contents hereof without obligation of ViewSonic to notify any person of such revision or changes.

Trademarks

Optiquest is a registered trademark of ViewSonic Corporation.

ViewSonic is a registered trademark of ViewSonic Corporation.

All other trademarks used within this document are the property of their respective owners.

Revision History

Revision	SM Editing Date	ECR Number	Description of Changes	Editor
1a	01/16/2006		Initial Release	Jamie Chang

TABLE OF CONTENTS

1. Precautions and Safety Notices	1
2. Specification	4
3. Front Panel Function Control Description	7
4. Circuit Description	14
5. Adjustment Procedure	21
6. Troubleshooting Flow Chart	40
7. Recommended Spare Parts List	43
8. Exploded Diagram and Exploded Parts List	53
9. Block Diagrams	56
10. Schematic Diagrams	57
11. PCB Layout Diagrams	65

1. Precautions and Safety Notices

1. Appropriate Operation

- (1) Turn off the product before cleaning.
- (2) Use only a dry soft cloth when cleaning the LCD panel surface.
- (3) Use a soft cloth soaked with mild detergent to clean the display housing.
- (4) Disconnect the power plug from AC outlet if the product is not used for a long period of time.
- (5) If smoke, abnormal noise, or strange odor is present, immediately switch the LCD display off.
- (6) Do not touch the LCD panel surface with sharp or hard objects.
- (7) Do not place heavy objects on the LCD display, video cable, or power cord.
- (8) Do not use abrasive cleaners, waxes or solvents for your cleaning.
- (9) Do not operate the product under the following conditions:
 - Extremely hot, cold or humid environment.
 - Areas susceptible to excessive dust and dirt.
 - Near any appliance generating a strong magnetic field.
 - Place in direct sunlight.

2. Caution

No modification of any circuit should be attempted. Service work should only be performed after you are thoroughly familiar with all of the following safety checks and servicing guidelines.

3. Safety Check

Care should be taken while servicing this LCD display. Because of the high voltage used in the inverter circuit, the voltage is exposed in such areas as the associated transformer circuits.

4. Power Supply Requirements

The external AC power operating range shall be from 90 to 264Vac

5. LCD Module Handling Precautions







5.1. Handling Precautions



- (1) Since front polarizer is easily damaged, pay attention not to scratch it.
- (2) Be sure to turn off power supply when inserting or disconnecting from input connector.
- (3) Wipe off water drop immediately. Long contact with water may cause discoloration or spots.
- (4) When the panel surface is soiled, wipe it with absorbent cotton or other soft cloth.
- (5) Since the panel is made of glass, it may break or crack if dropped or bumped on hard surface.
- (6) Since CMOS LSI is used in this module, take care of static electricity and insure human earth when handling.
- (7) Do not open nor modify the Module Assembly.
- (8) Do not press the reflector sheet at the back of the module to any directions.
- (9) In case if a Module has to be put back into the packing container slot after once it was taken out from the container, do not press the center of the CCFL Reflector edge. Instead, press at the far ends of the CFL Reflector edge softly. Otherwise the TFT Module may be damaged.
- (10) At the insertion or removal of the Signal Interface Connector, be sure not to rotate nor tilt the Interface Connector of the TFT Module.
- (11) After installation of the TFT Module into an enclosure (LCD monitor housing, for example), do not twist nor bend the TFT Module even momentary. At designing the enclosure, it should be taken into consideration that no bending/twisting forces are applied to the TFT Module from outside. Otherwise the TFT Module may be damaged.
- (12) Cold cathode fluorescent lamp in LCD contains a small amount of mercury. Please follow local ordinances or regulations for disposal.
- (13) Small amount of materials having no flammability grade is used in the LCD module.

The LCD module should be supplied by power complied with requirements of Limited Power Source (IEC60950 or UL1950), or be applied exemption.

- (14) The LCD module is designed so that the CFL in it is supplied by Limited Current Circuit (IEC60950 or UL1950). Do not connect the CFL in Hazardous Voltage Circuit.

5.2. Handling and Placing Methods

Correct Methods:	Incorrect Methods:
<p>Only touch the metal frame of the LCD panel or the front cover of the monitor. Do not touch the surface of the polarizer.</p>	<p>Surface of the LCD panel is pressed by fingers and that may cause "Mura"</p>
	
	
<p>Take out the monitor with cushions</p>	<p>Taking out the monitor by grasping the LCD panel. That may cause "Mura"</p>
	

<p>Place the monitor on a clean and soft foam pad.</p>	<p>Placing the monitor on foreign objects. That could scratch the surface of the panel or cause "Mura"</p>
	
	<p>The panel is placed facedown on the lap. That may cause "Mura"</p> 

2. Specification

1. General Requirements

General Specifications

Test Resolution & Frequency	“1280 x 1024” @ 60Hz
Test Image Size	Full Size
Contrast and Brightness Controls	Factory Default: Contrast = 70%, Brightness = 100%

2. Signal Interface

Video Interface

Analog Input Connector	DB-15 (Analog)
Default Input Connector	Defaults to the first detected input
Video Cable Connector DB-15 Pin out	Compliant DDC 1/2B.
Video Signals	1. Video RGB (Analog) Separate Sync
Video Impedance	75 Ohms (Analog), 100 Ohms (Digital)
Exclusions	Not compatible with interlaced video.

3. Power

Power Supply

Input Voltage Range	90 to 264 VAC
Power Dissipation	40 Watts (Typ.)

4. Electrical Requirements

Horizontal / Vertical Frequency

Horizontal Frequency	30 – 82 KHz
Vertical Refresh Rate	50 – 85 Hz * For resolution 1280 x 1024, the vertical Refresh rate up to 75 Hz; for there rest Resolutions, the vertical refresh rate up To 85Hz
Maximum Pixel Clock	135 MHz
Sync Polarity	Independent of sync polarity.

Timing Table

Item	Timing	Analog
1	640 x 350 @ 70Hz, 31.5kHz	Yes
2	640 x 400 @ 60Hz, 31.5kHz	Yes
3	640 x 400 @ 70Hz, 31.5kHz	Yes
4	640 x 480 @ 50Hz, 24.7kHz	Yes
5	640 x 480 @ 60Hz, 31.5kHz	Yes
6	640 x 480 @ 67Hz, 35.0kHz	Yes
7	640 x 480 @ 72Hz, 37.9kHz	Yes
8	640 x 480 @ 75Hz, 37.5kHz	Yes
9	640 x 480 @ 85Hz, 43.27kHz	Yes
10	720 x 400 @ 70Hz, 31.5kHz	Yes
11	800 x 600 @ 56Hz, 35.1kHz	Yes
12	800 x 600 @ 60Hz, 37.9kHz	Yes
13	800 x 600 @ 75Hz, 46.9kHz	Yes
14	800 x 600 @ 72Hz, 48.1kHz	Yes
15	800 x 600 @ 85Hz, 53.7kHz	Yes
16	832 x 624 @ 75Hz, 49.7kHz	Yes
17	1024 x 768 @ 60Hz, 48.4kHz	Yes
18	1024 x 768 @ 70Hz, 56.5kHz	Yes
19	1024 x 768 @ 72Hz, 58.1kHz	No
20	1024 x 768 @ 75Hz, 60.0kHz	Yes

21	1024 x 768 @ 85Hz, 68.67kHz	Yes
22	1152 x 864 @ 75Hz, 67.5kHz	No
23	1152 x 870 @ 75Hz, 68.7kHz	Yes
24	1280 x 1024 @ 60Hz, 63.4kHz	Yes
25	1280 x 1024 @ 75Hz, 79.97kHz	Yes
26	1280x 720 @ 60Hz, 45kHz (HDTV)	Yes

Changing Modes

Maximum Mode Change Blank Time for image stability. Note: 1) Excluding “Auto Adjust” time 2) Under DOS mode (640 x 350, 720 x 400 & 640 x 400), there is no “Auto Adjust” feature. 3) The monitor needs to do “Auto Adjust” the first time a new mode is detected.	Under 3 seconds (Maximum) 1 seconds (Typ.) for recognized timings 1-2 seconds (Typ.) for unrecognized timing
---	--

5. LCD Panel

Panel Characteristics

Panel Type	M190EN03V3
Type	VA type with LVDS interface
Active Size	376.32 (H) x 301.056 (V)
Pixel Arrangement	RGB Vertical Stripe
Pixel Pitch	0.294 mm
# of Backlights	4 CCFL edge-light (2 top / 2 bottom)
Backlight Life	40,000 Hours (minimum)
Panel Performance	
Luminance – Condition: CT = 6500K, Contrast = Max, Brightness = Max	250 cd/m ² (typ. after 30-minute warm-up) 200 cd/m ² (minimum after 30-minute warm-up)
Brightness Uniformity	80% (typ) 75% (min)
Contrast Ratio	1000:1 (typ.), 750:1 (minimum)
Color Depth	16.7M colors (RGB 8-bit data)
Viewing Angle (Horizontal)	170 degrees @ CR>10
Viewing Angle (Vertical)	170 degrees @ CR>10
Response Time 10%-90% @ Ta=25°C	14 ms (Tr= 9 ms, Tf= 5 ms) (typ.) 40 ms (Tr= 25 ms, Tf=15 ms) (maximum)

6. Mechanical

Dimensions

Width	414 mm
Height	407 mm
Depth	219 mm
Monitor Weight	5.4kg / 11.88 lbs

Ergonomics

Tilt Up	20 DEGREES MINIMUM
Tilt Down	-5 degrees

Package Specifications

Width	490 mm
Height	570 mm
Depth	145 mm
Gross Weight	6.8kg (14.96lb)

7. Environmental

Environmental Conditions

Operating Temperature	0°C to +40°C
Storage Temperature	-20°C to +60°C
Operating Relative Humidity	10% to 90% RH Non-Condensing
Storage Relative Humidity	5% to 90% RH Non-Condensing
Operating Altitude	0 to +3,000 meters
Storage Altitude	0 to +12,000 meters

3. Front Panel Function Control Description

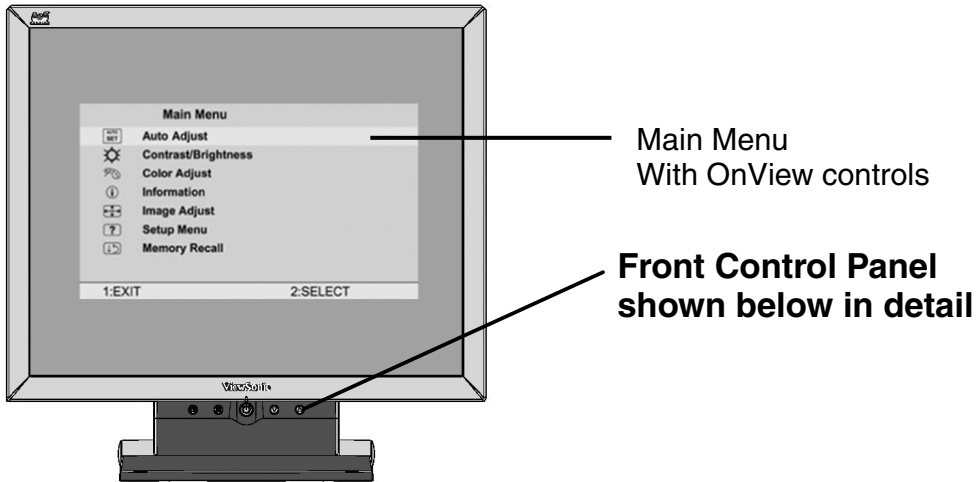

Displays the control screen for the highlighted control.

Also toggles between two controls on some screens.

Also a shortcut to Auto Image Adjust.



Displays the Main Menu. or exits the control screen and saves adjustments.



Power light
Green = ON
Orange = Power Saving

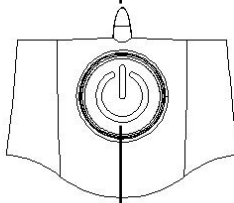

Power On/Off

Scrolls through menu options and adjusts the displayed control.

Also a shortcut to display the Contrast adjustment control screen.



Do the following to adjust the screen image:

- 1 To display the Main Menu, press button [1].

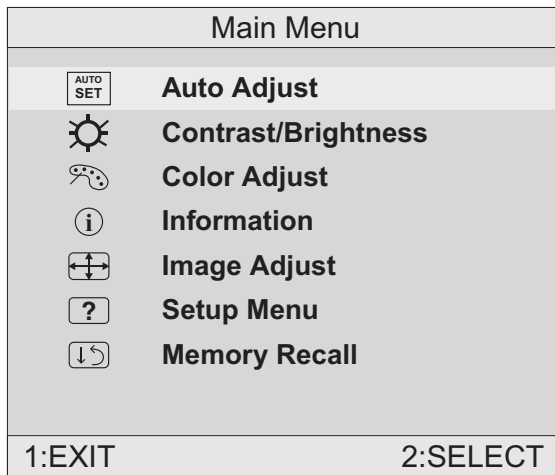

NOTE: All OnView menus and adjustment screens disappear automatically after about 15 seconds. This time period is adjustable through the Setup menu and the OSD timeout control described on page 11.

- 2 To highlight a control you want to adjust, press ▲ or ▼ to scroll up or down the Main Menu.
- 3 To select the highlighted control, press button [2]. A control screen appears like the example shown below.

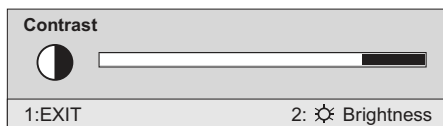

The line at the bottom of the screen tells you what you can do next: Exit or Select the control that is highlighted.

- 4 To adjust the control, press the up ▲ or down ▼ buttons.
- 5 To save the adjustments and exit the menu, press button [1] *twice*.

The following tips may help you optimize your display:

- Adjust your computer's graphic card so that it outputs a video signal 1280 x 1024 @ 60 Hz to the LCD display. (Look for instructions on “changing the refresh rate” in your graphic card's user guide.)
- If necessary, make small adjustments using H. POSITION and V. POSITION until the screen image is completely visible. (The black border around the edge of the screen should barely touch the illuminated “active area” of the LCD display.)

Main Menu Controls

Adjust the menu items shown below by using the up ▲ and down ▼ buttons.

Control Explanation



Auto Adjust automatically sizes, centers, and fine tunes the video signal to eliminate waviness and distortion.

Press the [2] button to obtain a sharper image.

NOTE: Auto Adjust works with most common video cards. If this function does not work on your LCD display, then lower the video refresh rate to 60 Hz and set the resolution to its pre-set value.



Contrast adjusts the difference between the image background (black level) and the foreground (white level).



Brightness adjusts background black level of the screen image.



Color Adjust provides several color options: preset color temperatures and User which allows you to adjust red (R), green (G), and blue (B). The factory setting for this product is 6500K (6500 Kelvin).

Color Adjust	
sRGB	
9300K	
● 6500K	
5400K	
User Color	
1:EXIT	2:SELECT

sRGB — sRGB is quickly becoming the industry standard for color management, with support being included in many of the latest applications. Enabling this setting allows the LCD display to more accurately display colors the way they were originally intended. Enabling the sRGB setting will cause the Contrast and Brightness adjustments to be disabled.

9300K — Adds blue to the screen image for cooler white (used in most office settings with fluorescent lighting).

6500K — Adds red to the screen image for warmer white and richer red. Default setting.

5400K — Adds green to the screen image for a darker color.

Control Explanation

User — Individual adjustments for red, green, and blue.

- 1 To select color (R, G or B) press button [2].
- 2 To adjust selected color, press ▲ or ▼.
- 3 When you are finished making all color adjustments, press button [1] *twice*.







Information displays the timing mode (video signal input) coming from the graphics card in your computer. See your graphic card's user guide for instructions on changing the resolution and refresh rate (vertical frequency).

VESA 1280 x 1024 @ 60 Hz (recommended) means that the resolution is 1280 x 1024 and the refresh rate is 60 Hertz.

Information	
H. Frequency:	48.60 KHz
V. Frequency:	60.00 Hz
Pixel Clock:	65.00 MHz
Resolution:	1280 x 1024
Model Number:	VS10047
Serial No:	
website : www.viewsonic.com	
1:EXIT	



Image Adjust

Image Adjust	
	H./V. Position
	H. Size
	Fine Tune
	Sharpness
1:EXIT	
2:SELECT	

The Image Adjust controls are explained below:



H./V. Position adjusts horizontal and vertical position of the screen image. You can toggle between Horizontal and Vertical by pressing button [2]. Horizontal moves the screen image to the left or to the right. Vertical moves the screen image up and down.



H. Size (Horizontal Size) adjusts the width of the screen image.

NOTE: Vertical size is automatic with your LCD display.

Control Explanation



Fine Tune sharpens focus by aligning the illuminated text and/or graphic characters.

NOTE: Try the **Auto Adjust** (see page 9) before using the **Fine Tune** control.



Sharpness adjusts the clarity and focus of the screen image.



Setup Menu displays the menu shown below.

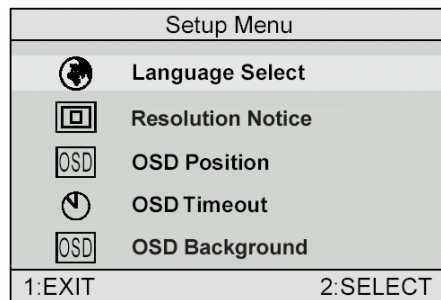

The Setup Menu controls are explained below.



Language Select allows you to choose the language used in the menus and control screens.



Resolution Notice advises the optimal resolution to use.

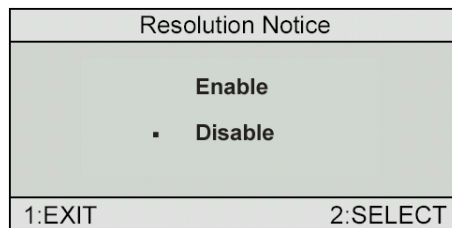

OSD Position allows you to move the on-screen display menus and control screens.



OSD Timeout sets the length of time an on-screen display screen is displayed. For example, with a “15 second” setting, if a control is not pushed within 15 seconds, the display screen disappears.

Control	Explanation
---------	-------------



OSD Background allows you to turn the On-Screen display background on or off. This means that while making adjustments from the OSD control screens you can also view open software applications, or the Windows desktop.



Memory Recall returns adjustments to the original factory settings if the display is operating in a factory Preset Timing Mode listed in this user guide.

Short Cut Key

Function Key : 5 Keys → 1 2   

[1]	Main Menu
[2]	Auto Image Adjust
[▼] or [▲]	to immediately activate Contrast menu. It should be change to Brightness OSD by push button [2].
[▼] + [▲]	recall Contrast or Brightness while in the Contrast or Brightness adjustment, or recall both of Contrast and Brightness when the OSD is not open.
[1] + [2]	toggle 720x400 and 640x400 mode when input 720x400 or 640x400 mode.
[1] + [▼] + [▲] (Keep pushing 5 sec)	White Balance.
[1] + [▼]	Power Lock
[1] + [▲]	OSD Lock

4. Circuit Description

A. Scaling controller

GENERAL DESCRIPTION

The TSU16AS is total solution graphics processing IC for LCD monitors with panel resolutions up to SXGA. It is configured with a high-speed integrated triple-ADC/PLL, a high quality display processing engine, and an integrated output display interface that can support LVDS panel interface format. To further reduce system costs, the TSU16AS also integrates intelligent power management control capability for green-mode requirements and spread-spectrum support for EMI management.

The TSU16AS incorporates the world's first coherent oversampled RGB graphics ADC in a monitor controller system¹. The oversampling ADC samples the input RGB signals at a frequency that is much higher than the signal source pixel rate. This can preserve details in the video signal that ordinarily would be lost due to input signal jitter or bandwidth limitations in non-oversampled systems.

The TSU16AS also incorporates a new Dynamic Frame Rate (DFR) generator² for the digital output video to the display panel that preserves the advantages of a fixed output clock rate, while eliminating the output end of frame short-line.

^{1,2} Patent Pending

PIN DESCRIPTION

CPU Interface

Pin Name Pin Type Function Pin

HWRESET Schmitt Trigger Input w/
5V-tolerant

Hardware reset; active high 5

INT Output CPU interrupt; 4mA driving strength 27

AD3 I/O w/ 5V-tolerant DDR direct bus AD3; 4mA driving strength 4

AD2 I/O w/ 5V-tolerant DDR direct bus AD2; 4mA driving strength 1

AD1 I/O w/ 5V-tolerant DDR direct bus AD1; 4mA driving strength 2

AD0 I/O w/ 5V-tolerant DDR direct bus AD0; 4mA driving strength 3

ALE I w/ 5V-tolerant DDR direct bus ALE; active high 24

WRZ I w/ 5V-tolerant DDR direct bus WRZ; active low 25

RDZ I w/ 5V-tolerant DDR direct bus RDZ; active low 26

Analog Interface

Pin Name Pin Type Function Pin

HSYNC Schmitt Trigger Input w/
5V-tolerant

Analog HSYNC input 8

VSYNC Schmitt Trigger Input w/
5V-tolerant

Analog VSYNC input 9

REFP Internal ADC top de-coupling pin 22

REFM Internal ADC bottom de-coupling pin 23

RINP Analog Input Analog red input 19

RINM Analog Input Reference ground for analog red input 18

SOGIN Analog Input Sync-on-green input 17

GINP Analog Input Analog green input 16

GINM Analog Input Reference ground for analog green input 15

BINP Analog Input Analog blue input 14

BINM Analog Input Reference ground for analog blue input 13

REXT External resistor 390 ohm to AVDD_ADC 11

LVDS Interface

Pin Name Pin Type Function Pin

LVA0M Output A-Link Negative LVDS Differential Data Output 42

LVA0P Output A-Link Positive LVDS Differential Data Output 41

LVA1M Output A-Link Negative LVDS Differential Data Output 40

TSU16AS

SXGA LCD Controller with Analog Interface and Dual LVDS Transmitter

Preliminary Data Sheet Version 0.2

Version 0.2 - 5 - 10/1/2004

Copyright © 2004 MStar Semiconductor, Inc. All rights reserved.

Pin Name Pin Type Function Pin

LVA1P Output A-Link Positive LVDS Differential Data Output 39
LVA2M Output A-Link Negative LVDS Differential Data Output 38
LVA2P Output A-Link Positive LVDS Differential Data Output 37
LVA3M Output A-Link Negative LVDS Differential Data Output 34
LVA3P Output A-Link Positive LVDS Differential Data Output 33
LVACKM Output A-Link Negative LVDS Differential Clock Output 36
LVACKP Output A-Link Positive LVDS Differential Clock Output 35
LVB0M Output B-Link Negative LVDS Differential Data Output 52
LVB0P Output B-Link Positive LVDS Differential Data Output 51
LVB1M Output B-Link Negative LVDS Differential Data Output 50
LVB1P Output B-Link Positive LVDS Differential Data Output 49
LVB2M Output B-Link Negative LVDS Differential Data Output 48
LVB2P Output B-Link Positive LVDS Differential Data Output 47
LVB3M Output B-Link Negative LVDS Differential Data Output 44
LVB3P Output B-Link Positive LVDS Differential Data Output 43
LVBCKM Output B-Link Negative LVDS Differential Clock Output 46
LVBCKP Output B-Link Positive LVDS Differential Clock Output 45

GPO Interface

Pin Name Pin Type Function Pin

PWM1 Output PWM1; 4mA driving strength 29

PWM0 Output PWM0; 4mA driving strength 28

Misc. Interface

Pin Name Pin Type Function Pin

XIN Crystal Oscillator Input Xin 6

XOUT Crystal Oscillator Output Xout 7

VCTRL Output Regulator Control 54

Power Pins

Pin Name Pin Type Function Pin

AVDD_ADC 3.3V Power ADC Power 12, 20

VDDP 3.3V Power Digital Output Power 30, 53

DDC 1.8V Power Digital Core Power 32, 55

GND Ground Ground 10, 21, 31, 56

ELECTRICAL SPECIFICATIONS

Analog Interface Characteristics

Parameter Min Typ Max Unit

Resolution 8 Bits

DC ACCURACY

Differential Nonlinearity $\pm 0.5 + 1.50 / -1.0$ LSB

Integral Nonlinearity ± 1 LSB

No Missing Codes Guaranteed

ANALOG INPUT

Input Voltage Range

Minimum 0.5 V p-p

Maximum 1.0 V p-p

Input Bias Current 1 μ A

Input Full-Scale Matching 1.5 %FS

Brightness Level Adjustment 62 %FS

SWITCHING PERFORMANCE

Maximum Conversion Rate 220 MSPS

Minimum Conversion Rate 12 MSPS

HSYNC Input Frequency 15 200 kHz

PLL Clock Rate 12 220 MHz

PLL Jitter 500 ps p-p

Sampling Phase Tempco TBD ps/|C

DIGITAL INPUTS

Input Voltage, High (VIH) 2.5 V

Input Voltage, Low (VIL) 0.8 V

Input Current, High (IIH) -1.0 uA
Input Current, Low (IIL) 1.0 uA
Input Capacitance 5 pF
DIGITAL OUTPUTS
Output Voltage, High (VOH) VDDP-0.1 V
Output Voltage, Low (VOL) 0.1 V
DYNAMIC PERFORMANCE
Analog Bandwidth, Full Power 250 MHz
Channel to Channel Matching 0.5% Full-Scale
Specifications are subjected to change without notice.

TSU16AS

SXGA LCD Controller with Analog Interface and Dual LVDS Transmitter
Preliminary Data Sheet Version 0.2

Version 0.2 - 7 - 10/1/2004

Copyright © 2004 MStar Semiconductor, Inc. All rights reserved.

Absolute Maximum Ratings

Parameter Symbol Min Typ Max Units

3.3V Supply Voltages VVDD_33 -0.3 3.6 V
1.8V Supply Voltages VVDD_18 -0.3 1.98 V
Input Voltage (5V tolerant inputs) VIN5Vtol -0.3 5.0 V
Input Voltage (non 5V tolerant inputs) VIN -0.3 VVDD_33 V
Ambient Operating Temperature TA 0 70 °C
Storage Temperature TSTG -40 150 °C
Junction Temperature TJ 150 °C
Thermal Resistance (Junction to Air) Natural
Conversion
θJA TBD °C /W
Thermal Resistance (Junction to Case) Natural
Conversion
θJC TBD °C /W

Note: Stress above those listed under Absolute Maximum Rating may cause permanent damage to those indicated in the stress rating only; functional operation of the device at these or any other conditions outside of those indicated in the operation sections of this specification is not implied. Exposure to absolute maximum ratings foextended periods may affect device reliability.

ORDERING GUIDE

Model Temperature

Range

Package

Description

Package

Option

TSU16AS 0°C to +70°C SDIP

MTV512M64

The MTV512M micro-controller is an 8051 CPU core embedded device especially tailored for flat panel display applications. It includes an 8051 CPU core, 768-byte SRAM, 4 channels of 6-bit ADC, 3 external counters/timers, 6 channels of PWMDAC, VESA DDC interface, and a 64K-byte internal program Flash-ROM memory.

FEATURES

- 8051 core, CPU operating frequency up to 24MHz
- 3.3V power supply
- 768-byte RAM; 64K-byte program Flash memory
- Maximum 6 channels of PWM DAC
- Compliant with VESA DDC1/2B/2Bi/2B+/CI standard
- Watchdog timer with programmable interval
- Support external counters/timers, T0, T1, and ET2
- Single/double frequency clock output

- Two clock output ports
- Two external interrupts, INT1 is shared with Slave IIC interrupt source
- Maximum 4 channels of 6-bit ADC
- Flash-ROM code protection selection
- Hardware ISP (In System Programming), no Boot Code required
- Embedded Dual Ports DDCRAM (128-byte x 2)
- Green products like Pb-Free Packages or All Green Packages available

PIN CONFIGURATION & DESCRIPTION

A “CMOS output pin” means it can sink and drive at least 4mA current. It is not recommended to use such pin as input function.

An “open drain pin” means it can sink at least 4mA current. It can be used as input or output function and needs an external pull up resistor.

An “8051 standard pin” is a pseudo open drain pin. It can sink at least 4mA current when output is at low level, and drives at least 4mA current for 160nS when output transits from low to high, then keeps driving at 120 uA to maintain the pin at high level. It can be used as input or output function. It needs an external pull up resistor when driving heavy load device.

There is an internal pull-up resistance on each CMOS PAD and an internal pull-down resistance on each input

Low Power Reset (LVR) & Watchdog Timer

When the voltage level of power supply is below 2.4V (+/-0.4V) for a specific period of time, the LVR generates a chip reset signal. After the power supply is above 2.4V (+/-0.4V)

INVERTER

In order to drive the CCFLs embedded in the panel module, there is a half bridge inverter to convert by the controller.

The input 12V up to hundreds of AC voltage output.

The inverter is formed by symmetric in order to drive the separate lamp modules.

The input stage consists of a PWM controller, half bridge inverter, and switching MOSFET to convert DC input into AC output.

The output stage consists of a tuning capacitor, coupling capacitor, transformer, push-pull MOSFET pair to boost AC output up to hundreds of voltage.

And one resistor is serial to lamp for output voltage feedback.

There are two signal to control the inverter which come from system.

Logic “high” level which send to I901 is turn on the inverter.

BRI signal control brightness by DC level which was integral from PWM signal.

5. Adjusting Procedure

1. Function Test

1.1. Product

- 19" LCD Monitor

1.2. Test Equipment

- Color Video Signal & Pattern (or PC with SXGA resolution and a sound card)

1.3. Test Condition

Before function test and alignment, each LCD Monitor should be run-in and warmed up for at least 30 minutes with the following conditions:

- (a) In room temperature,
- (b) With full-white screen, RGB, and Black
- (c) With cycled display modes,
 - 640*480 (H=43.27kHz, V=85Hz)
 - 800*600 (H=53.7kHz, V=85Hz)
 - 1024*768 (H=68.67kHz, V=85Hz)
 - 1280*1024 (H=79.97kHz, V=75Hz)

1.4. Test Display Modes & Pattern

1.4.1 Compatible Modes

Item	Timing
1	640 x 350 @ 70Hz, 31.5kHz
2	640 x 400 @ 60Hz, 31.5kHz
3	640 x 400 @ 70Hz, 31.5kHz
4	640 x 480 @ 50Hz, 24.7kHz
5	640 x 480 @ 60Hz, 31.5kHz
6	640 x 480 @ 67Hz, 35.0kHz
7	640 x 480 @ 72Hz, 37.9kHz
8	640 x 480 @ 75Hz, 37.5kHz
9	640 x 480 @ 85Hz, 43.27kHz
10	720 x 400 @ 70Hz, 31.5kHz
11	800 x 600 @ 56Hz, 35.1kHz
12	800 x 600 @ 60Hz, 37.9kHz
13	800 x 600 @ 75Hz, 46.9kHz
14	800 x 600 @ 72Hz, 48.1kHz
15	800 x 600 @ 85Hz, 53.7kHz
16	832 x 624 @ 75Hz, 49.7kHz
17	1024 x 768 @ 60Hz, 48.4kHz
18	1024 x 768 @ 70Hz, 56.5kHz
19	1024 x 768 @ 72Hz, 58.1kHz
20	1024 x 768 @ 75Hz, 60.0kHz
21	1024 x 768 @ 85Hz, 68.67kHz
22	1152 x 864 @ 75Hz, 67.5kHz
23	1152 x 870 @ 75Hz, 68.7kHz
24	1280 x 1024 @ 60Hz, 63.4kHz
25	1280 x 1024 @ 75Hz, 79.97kHz
26	1280x 720 @ 60Hz, 45kHz (HDTV)

1.4.2 Function Test Display Pattern

Item	Test Content	Pattern	Specification	Remark
1	Frequency & Tracking	Fine Line Moire	Eliminate visual wavy noise.	Figure 1
2	Contrast/Brightness	16 Gray Scale	16 gray levels should be distinguishable.	Figure 2
3	Boundary	Horizontal & Vertical Thickness	Horizontal and Vertical position of video should be adjustable to be within the screen frame.	Figure 3
4	RGB Color Performance	RGB Color Intensities	Contrast of each R, G, B, color should be normal.	Figure 4, 5, 6
5	Screen Uniformity & Flicker	Full White	Should be compliant with the spec.	Figure 7
6	Dead Pixel/Line	White Screen & Dark Screen	The numbers of dead pixels should be compliant with the spec.	Figure 7, 8
7	White Balance	White & Black Pattern	The screen must have the pure white and black pattern, no other color.	Figure 9

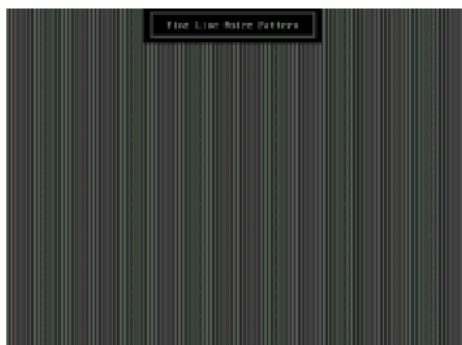

Fine Line Morie Pattern (Figure1)



Gray Scale Pattern (Figure2)



Horizontal & Vertical Thickness Pattern (Figure 3)



R. Color Pattern (Figure 4)



G. Color Pattern (Figure5)

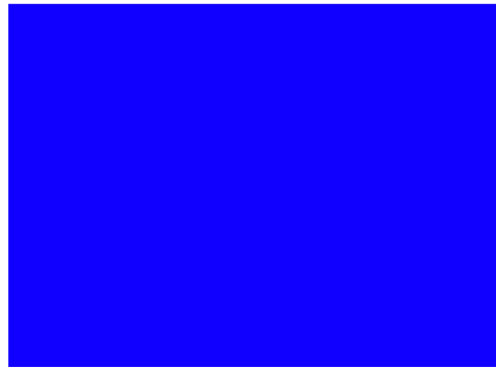

B. Color Pattern (Figure 6)



Full White Patter (Figure 7)



Dark Screen Pattern (Figure 8)

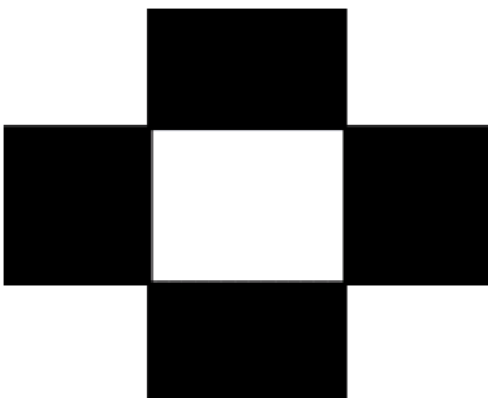

Black-White Pattern (Figure 9)

1.5. Function Test and Alignment Procedure

1.5.1 All Modes Reset

You should do “All Mode Reset” (Refer to Chapter III-3. Hot Keys for Function Controls) first. This action will allow you to erase all end-user’s settings and restore the factory defaults.

1.5.2 Auto Image Adjust

Please select and enter “*Auto Image Adjust*” function on Main Menu to see if it is workable. The “*Auto Image Adjust*” function is aimed to offer a better screen quality by built-in ASIC. For optimum screen quality, the user has to adjust each function manually.

1.5.3 Firmware

Test Pattern: Burn In Mode (Refer to Chapter III-3. Hot Keys for Function Controls)
- Make sure the F/W is the latest version.

1.5.4 DDC

Test Pattern: EDID program
- Make sure it can pass test program.

1.5.5 Fine Tune and Sharpness

Test Signal: 1280*1024@60Hz
Test Pattern: Line Moire Pattern
- Check and see if the image has noise and focus performs well. Eliminate visual line bar.
- If not, readjust by the following steps:
(a) Select and enter “**Fine Tune**” function on “**Manual Image Adjust**” to adjust the image to eliminate visual wavy noise.
(b) Then, select and enter “**Sharpness**” function to adjust the clarity and focus of the screen image.

1.5.6 Boundary

Test Signal: 1280*1024@60Hz
Test Pattern: Horizontal & Vertical Line Thickness Pattern
- Check and see if the image boundary is within the screen frame.
- If not, readjust by the following steps:
(a) Select and enter “**Manual Image Adjust**” function on OSD Main Menu.
(b) Then, select and enter “**Horizontal Size**” or “**Horizontal/Vertical Position**” function to adjust the video boundary to be full scanned and within screen frame.

1.5.7 White Balance

- A. TIMING: 1280x1024 64KHz/60Hz.
- B. PATTERN: 5 Blocks.
- C. LCD MONITOR set to 1280x1024 80K/75Hz BURN IN and warm up over 30 minutes.
- D. CA110 color analyzer at the center of screen and along a perpendicular to the screen at 20cm from the display.
- E. Power turn off, Press “▲” and “[2]” and turn on power at the same time after power LED is on, release “▲” and “[2]” key, Then press “[1]” key go to factory mode. (Fig.1)

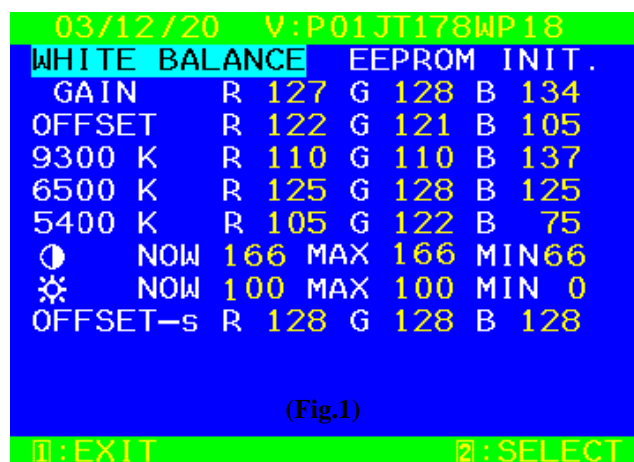

(Fig.1)

F. Adjust Color Temperature:

(1) EEPROM INIT (5 BLOCKS):

Press “▼” key move cursor to EEPROM INIT, Press “2” key then monitor will INIT ADC value.

(2) Press “▲” key move cursor to “White Balance”, Press “2” key do white balance adjustment.

(3) Press “▼” key move cursor to “Color Temperature Adjust”, Press “2” key, Then OSD will display Fig.2



(Fig.2)

(4) 9300K verify: move cursor to 9300K Press “2” key.

Press “▼”, “▲” key adjust R.G.B value

$x=0.283 \pm 0.02$

$y=0.298 \pm 0.02$

Press “1” key return to Fig.2

(5) 6500K verify: Repeat (4) press “▼”, “▲” move cursor to 6500K press “2” key

$x=0.313 \pm 0.02$

$y=0.329 \pm 0.02$

(6) 5400K verify: Repeat (4) press “▼”, “▲” move cursor to 5400K press “2” key

$x=0.332 \pm 0.02$

$y=0.348 \pm 0.02$

(7) Press “1” key go back to Fig.2, Then press “1” key return to Fig.1, Power key OFF/ON quit factory mode.

G. Color Temperature & Luminance Verify:

BRIGHTNESS MAX, CONTRAST MAX

9300K: $x=0.283 \pm 0.02$ $y=0.298 \pm 0.02$

6500K: $x=0.313 \pm 0.02$ $y=0.329 \pm 0.02$

5400K: $x=0.332 \pm 0.02$ $y=0.348 \pm 0.02$

1.5.8 R, G, B, Colors Contrast

Test Signal: 1280*1024@60Hz

Test Pattern: R, G, B, Color Intensities Pattern and 16 Gray Scale Pattern

- Check and see if each color is normal and distinguishable.

- If not, please return the unit to repair area.

1.5.9 Screen Uniformity and Flicker

Test Signal: 1280*1024@60Hz

Test Pattern: Full White Pattern

- Check and see if it is in normal condition.

1.5.10 Dead Pixel and Line

Test Signal: 1280*1024@60Hz

Test Pattern: Dark and White Screen Pattern

- Check and see if there are dead pixels on LCD panel with shadow gauge and filter film.
- The total numbers and distance of dead pixels should be compliant with the spec.

1.5.11 Mura

Test Pattern: White, RGB, Black, & Grey

Test Tool: 8% ND Filter

- Check if the Mura can pass 8% ND Filter.

1.5.13 Check for Secondary Display Modes

Test Signal:

Analog: 640*350@70Hz; 640*480@60HZ

720*400@70Hz; 800*600@60HZ/70HZ/75HZ

832*624@75Hz, 1024*768@60HZ/70HZ/75HZ

1280*1024@60/75Hz

- Normally when the primary mode 1280*1024@60Hz is well adjusted and compliant with the specification, the secondary display modes will be great possible to be compliant with the spec. But we still have to check with the general test pattern to make sure every secondary is compliant with the specification.

1.5.14 All Modes Reset

After final QC step, we have to erase all saved changes again and restore the factory defaults. You should do “All Mode Reset” again.

1.5.15 Power Off Monitor

Turn off the monitor by pressing “Power” button.

2. Firmware Upgrade Procedure

When you receive the returned monitor, please check whether the firmware version is the latest. If not, please do the following procedures to upgrade it to the latest version.

2.1. Equipment Needed

- VA902/b-2 Monitor
- Fixture for Firmware Upgrade
- VGA Cable
- PC (Personal Computer)
- LPT Cable
- Firmware Upgrade Program
- One additional monitor for checking the program execution

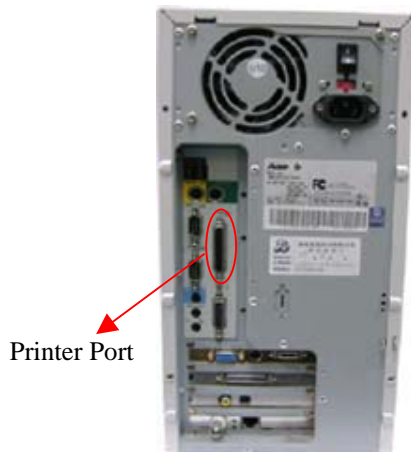

PC



VA902/b-2



LPT Cable



VGA Cable

2.2. Setup Procedure

- 2.2.1 Connect P2 of Fixture with printer port of PC by LPT Cable.
- 2.2.2 Connect P1 of Fixture with VA902/b-2 Monitor by VGA Cable.
- 2.2.4 Connect Power Cord to VA902/b-2 Monitor.
- 2.2.5 Connect PC to the additional monitor.

2.3. ISP Download program procedure

- 2.3.1 Hardware Connect status:

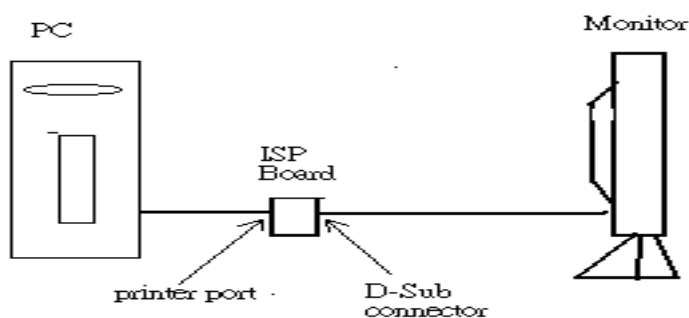

- 2.3.2 Down load isp program

Step 1: Execute ISP.exe



Step 2: Select MCU type

Pressing the Comb box to select the type of the MCU , It need to be selected the **MTV512M64** for this project. Then press the **Creat Security File** Button to enter step 3.



Step 3: Creat Security File

Enter the three string into the blank like fig 2. Then press OK Button.

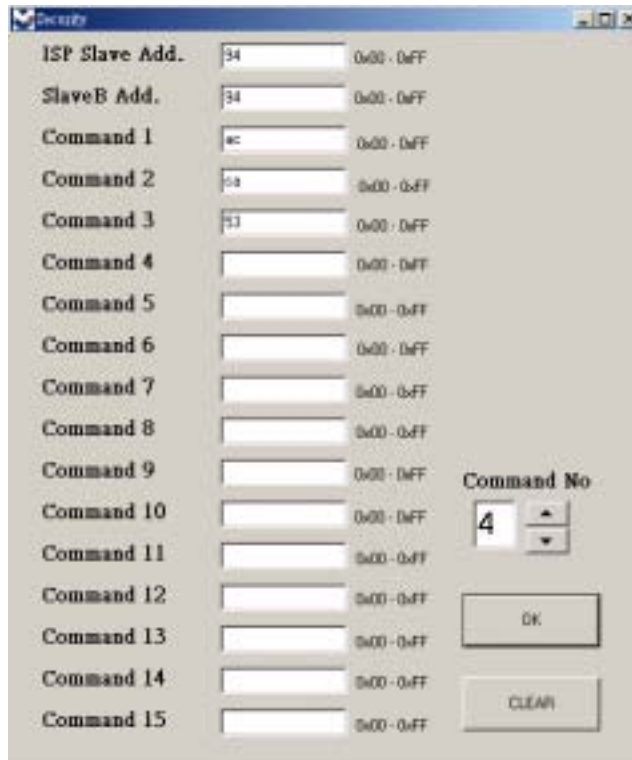

Step 4: Load file

Press the Load MCU File button to select the file will be download. (*.hex)

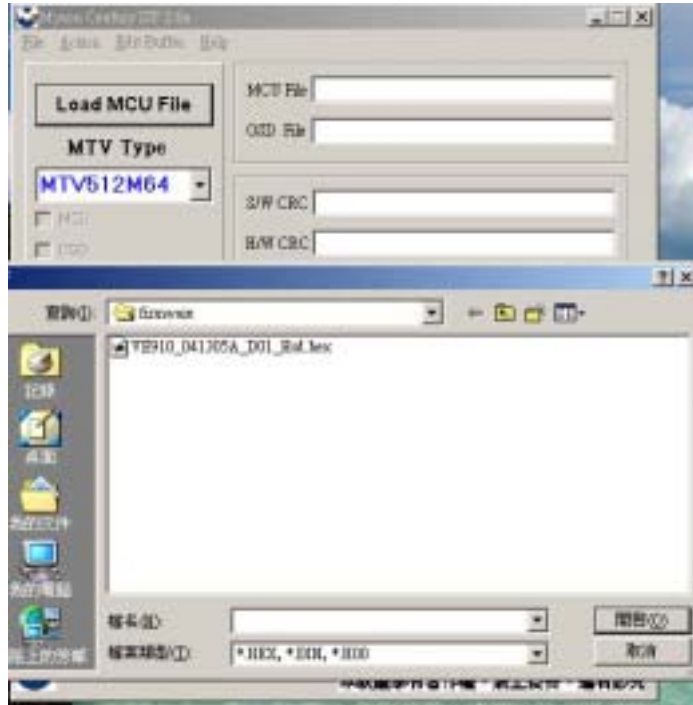

Step 5: Run

Pressing the Run Button to start download program. Press OK button to Enter ISP mode.



Step 6: Download program finish

Pressing the OK Button to finish the download program procedure.



Trouble shooting:

If you find the status like the follow picture. Please check the following item.

- The connecting status between PC and ISP board.
- The connecting status between ISP status and Monitor.

Turn off the power of monitor (AC plug off) and disconnect the D-Sub connector . To connect the D-Sub connector and then turn on the power of monitor.(AC plug on)



If the test result shows “passed,” it means the connection is well. If not (failed), it means the connection has problems. Then you need to check the setup procedure or reboot the PC, or simply use another PC to do the firmware upgrade.

3. DDC Key In Procedure

Note:

1. Every time after replacing the main board, you have to do the DDC key in.
2. If you find the DDC does not conform to the monitor, you have to do the DDC key in.

3.1. Equipment Needed

- VA902/b-2 Monitor
- DDC Card
- PC
- RS232 cable
- Barcode Reader
- VGA Cable



VA902/b-2



DDC Card



PC



RS-232 Cable



VGA Cable



Barcode Reader

3.2. Setup Procedure

3.2.1 Connect VGA Card and DDC Card with RS-232 cable.



3.2.2 Barcode Reader connect with keyboard and PC keyboard port.



3.2.3 Connect RS-232 Cable and VA902(2) with VGA Cable.

(when key in DVI DDC information, use VGA transform to DVI port)

3.2.4 Connect Power Cord to VA902(2) Monitor.

3.3. DDC Key In Procedure

3.3.1 Run DDC.exe

3.3.2 Choose model number and conform the Time then Press “ENTER” key.



3.3.3 When appear the PIC “ choose DDC Card”, Press ALT+2 Enter DDC 2B test interface.

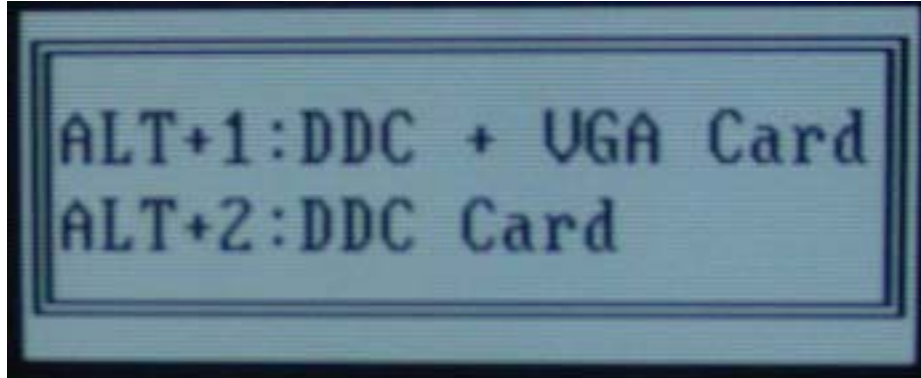

Choose DDC Card

3.3.4 Press F8 to choose corresponding model.DAT (VA902(2).DAT press “ENTER” key)

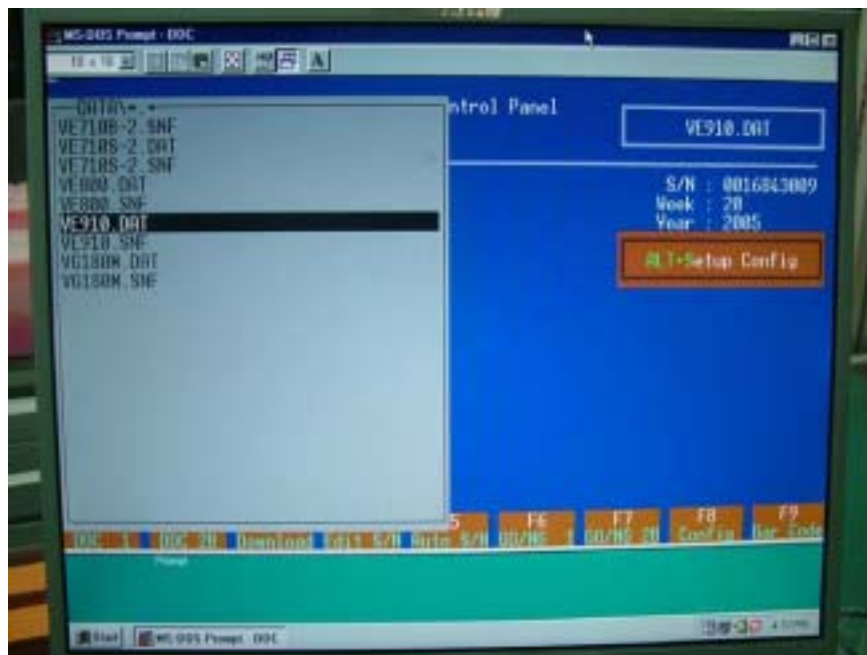

3.3.5 Press F9 enter the download interface

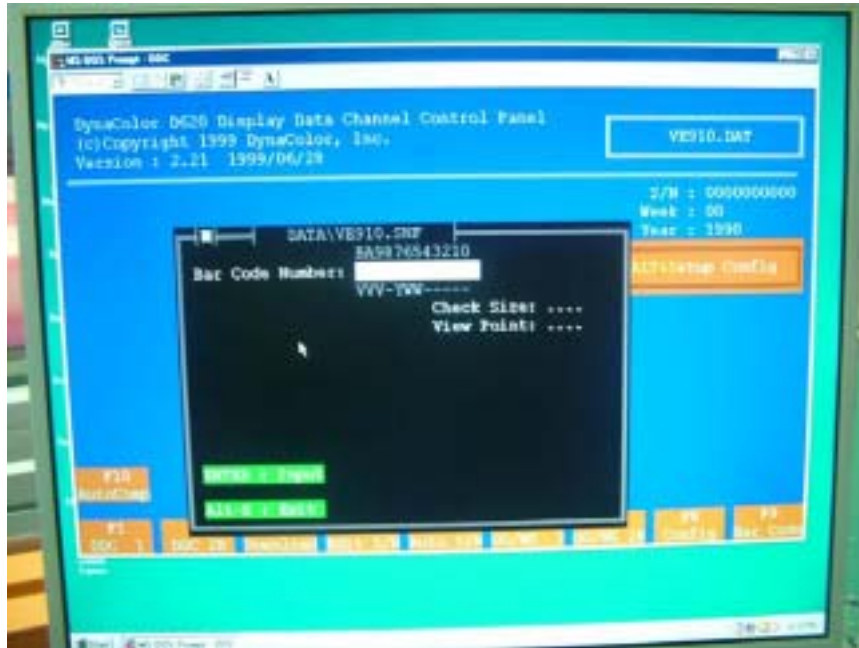

3.3.6 Key in the serial number or use the barcode reader to scan the barcode of the monitor, and press “ENTER” key.

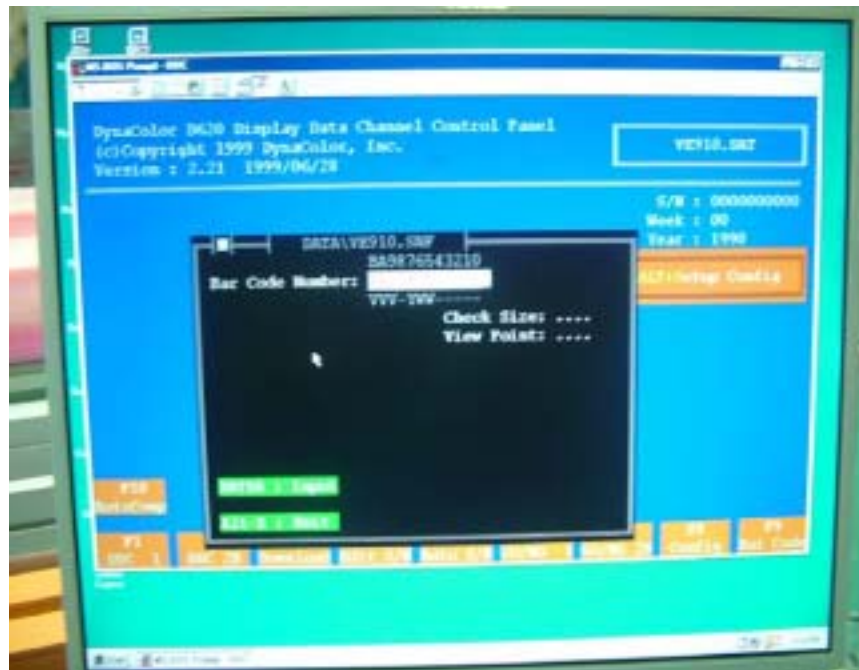

3.3.7 The successful picture is as follows. "Compare EDID : OK! Press any key to continue".

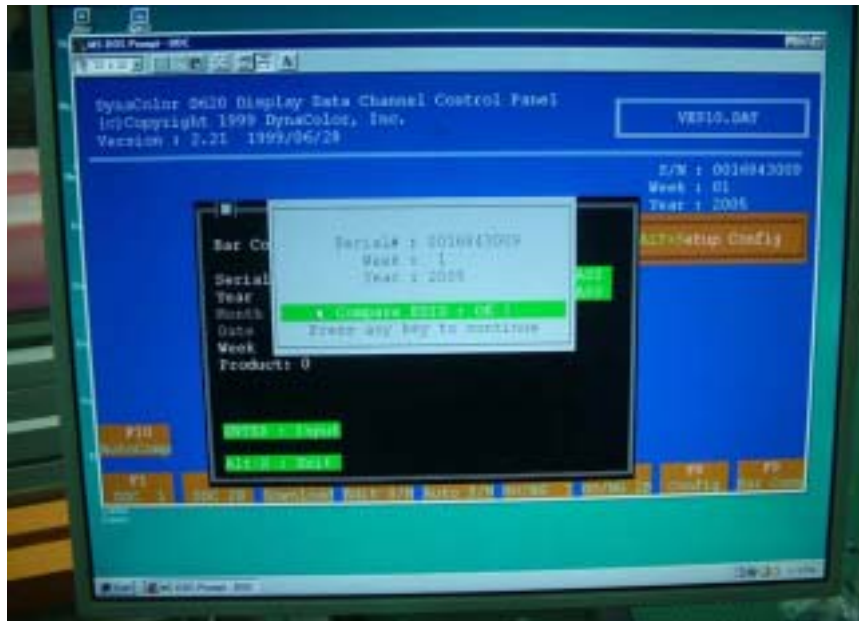

3.3.8 Let VA902(2) active then see the information in OSD, it shows "Serial NO : PPZ0517A3178"

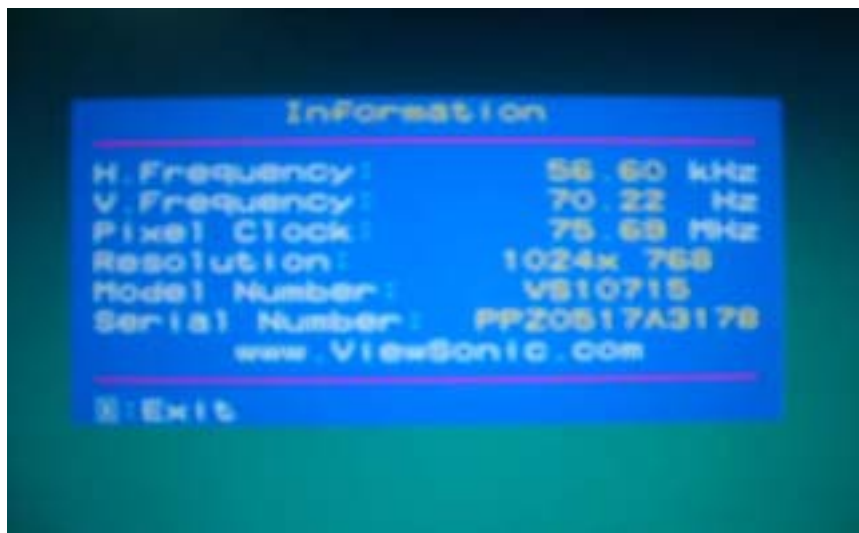

3.4. Check Method

Use ViewSonic EDID Editor

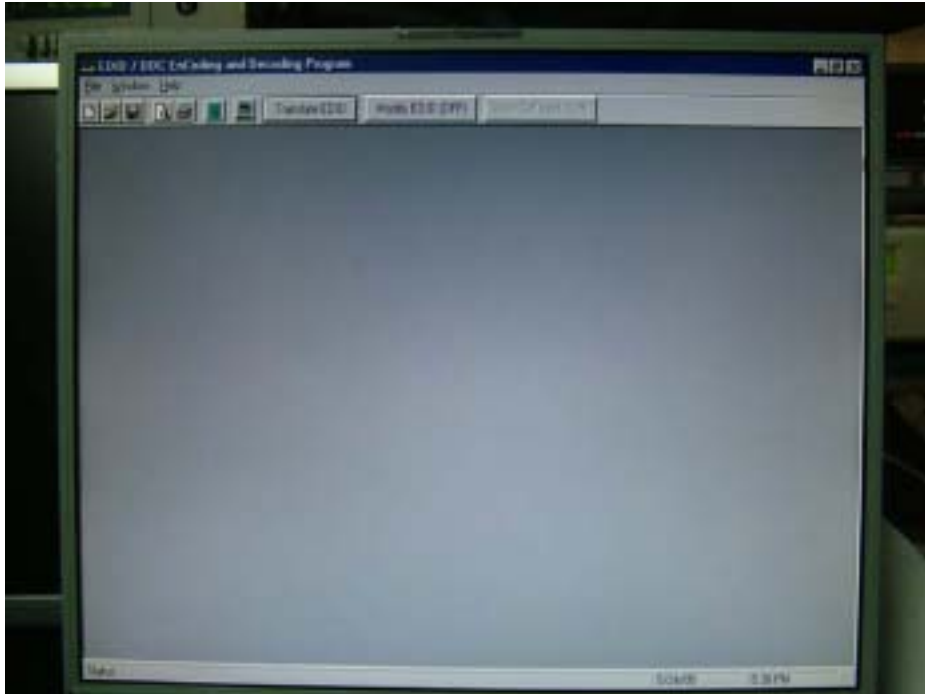

Connect the VA902(2) to PC with VGA Cable. Excute the EDID Editor, then Press Ctrl+F5. If the DDC is correct, you can see the information as follow:

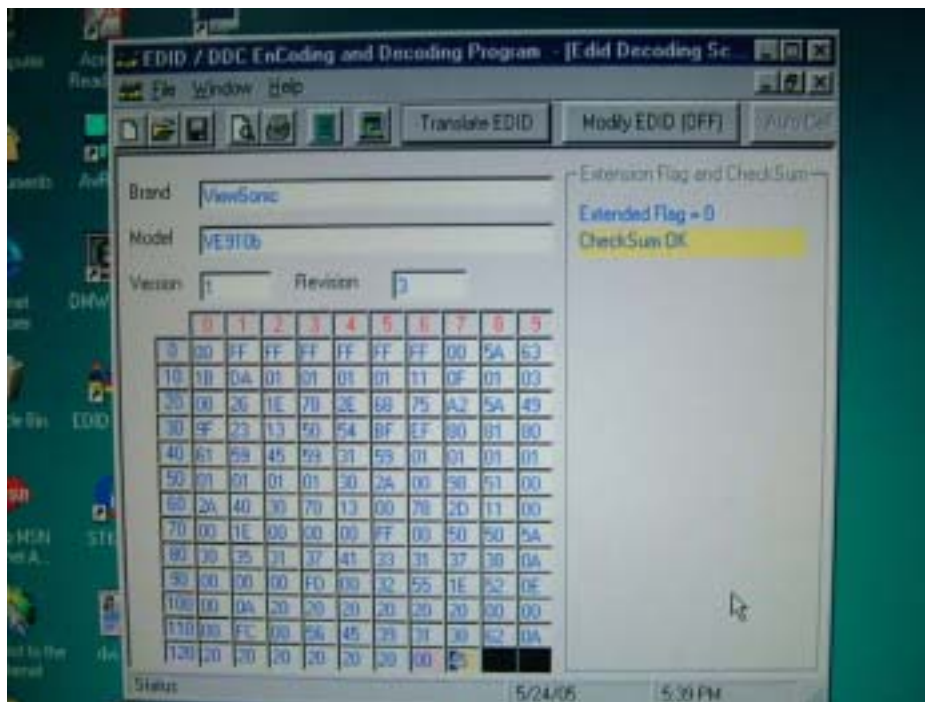

Packing For Shipping

1. Packing Procedure

1.1 Paste protection film to protect the monitor. (Figure 1)

1.2 Put the monitor in the PE bag and seal the bag with tape. (Figure 2)



Figure 1



Figure 2

1.3 Put the cushions on the monitor. (Figure 3)

1.4 Place the monitor into the carton and then put all the accessories into the carton. At last, close the carton and seal it with tape. (Figure 4)



Figure 3

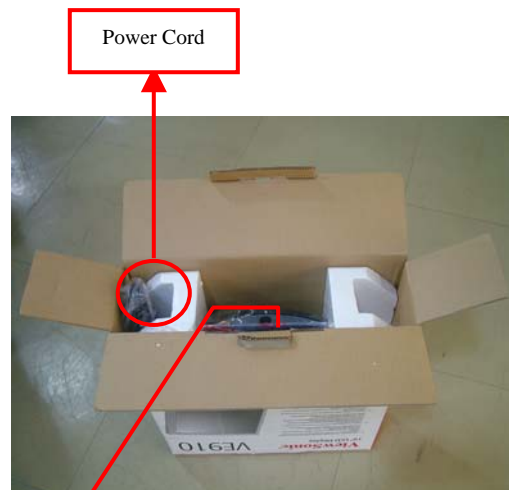

Figure 4

Disassembly Procedure

1. Disassembly of Stand unit from Monitor

1.1 Remove two Hinge Cover.



1.2 Unscrew four screws that secure Stand Unit.



1.3 Detach Stand Unit from the monitor.



2. Disassembly of Front Cover and Rear Cover

2.1 Unscrew two screws that secure Rear Cover to remove Front Cover.



2.2 Unscrew 2 screws to remove Rear Cover.

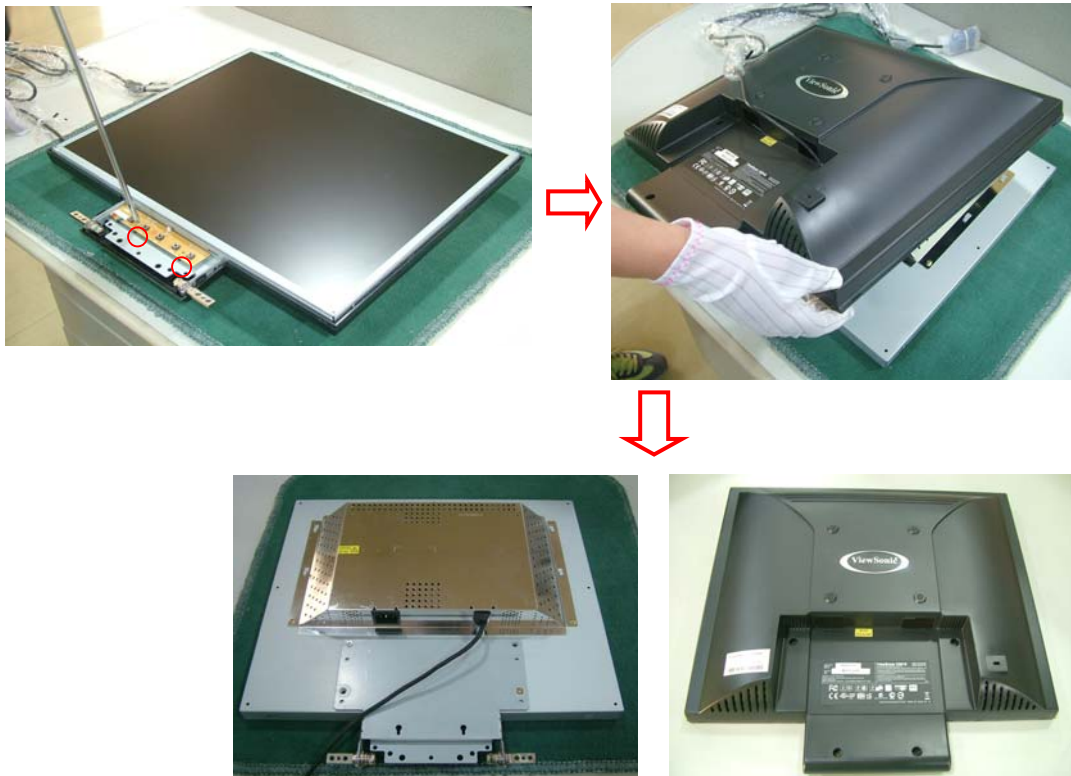

3. Disassembly of Hinge, Main Board, Keypad Board and Panel Unit

3.1 Unscrew 4 screws to remove Hinge.

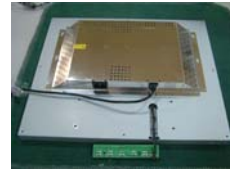
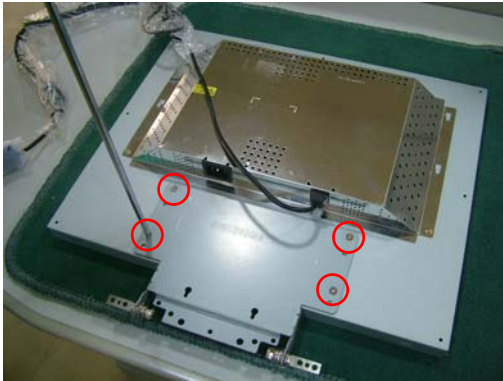

Hinge

3.2. Unscrew 2 screws to remove Shielding Plate.

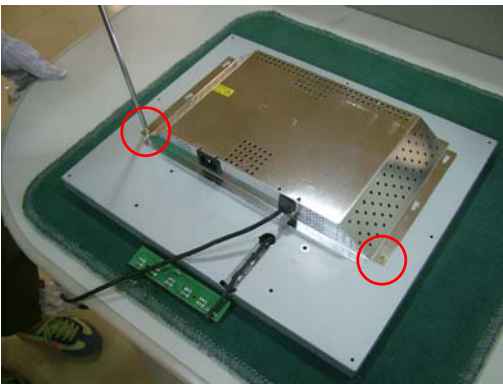

Shielding Plate

3.3. Unscrew 2 screws and disconnect the connector to remove VGA Cable.



VGA Cable

3.4. Unscrew 7 screws and disconnect the wires to remove Main Board.

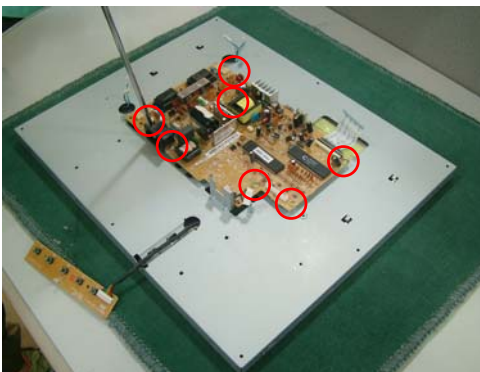

Main Board

3.5. Lay Panel Unit facedown and unscrew 4 screws on its right and left sides to remove Panel Unit and Keypad Board.

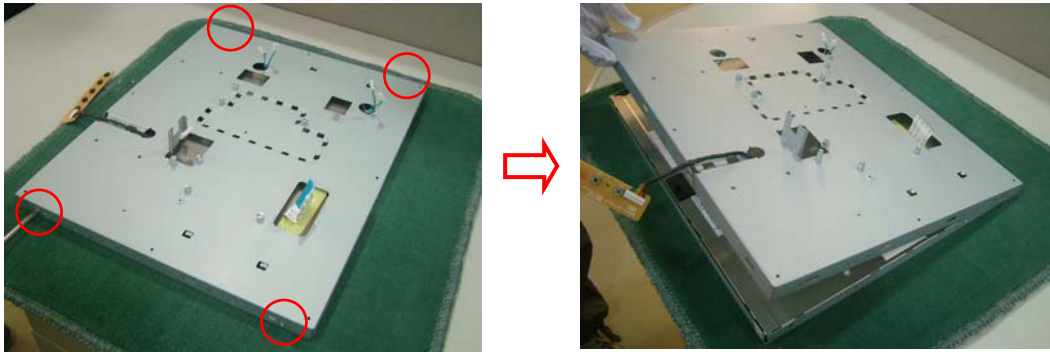

Keypad Board



Panel Bracket



Panel Unit

6. Trouble Shooting Flow Chart

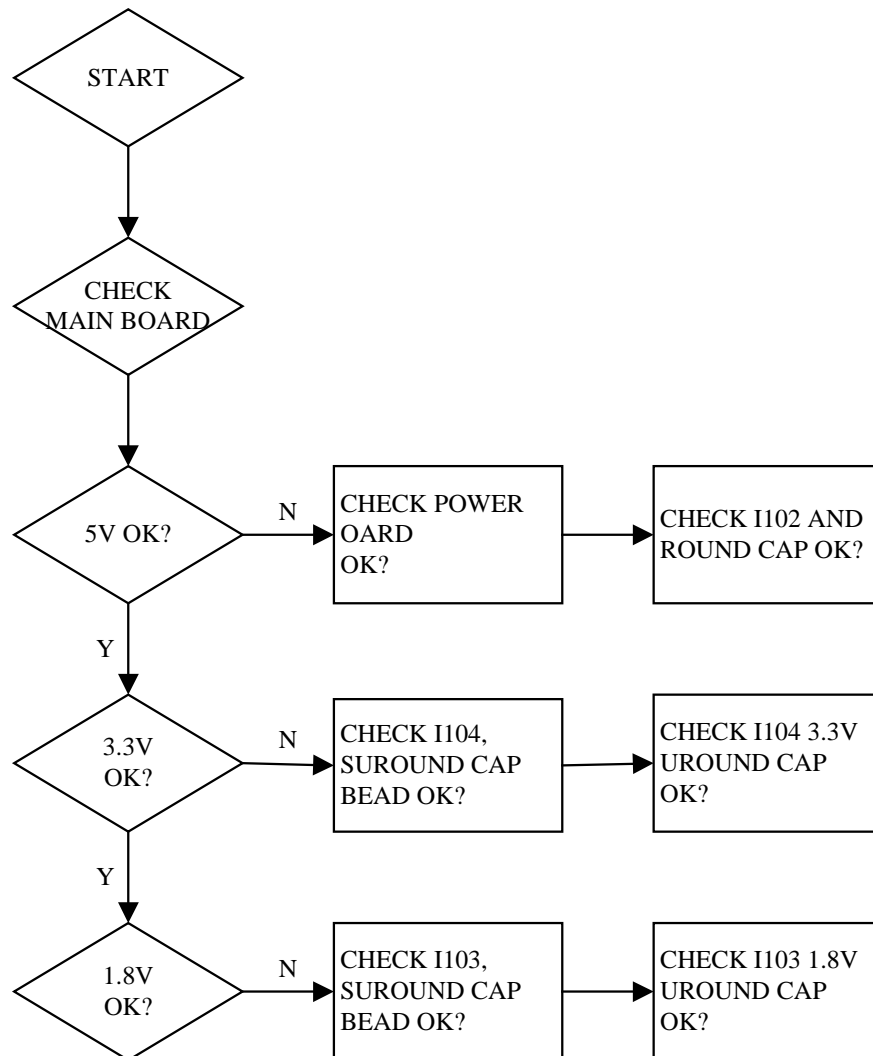

6.1. NO POWER

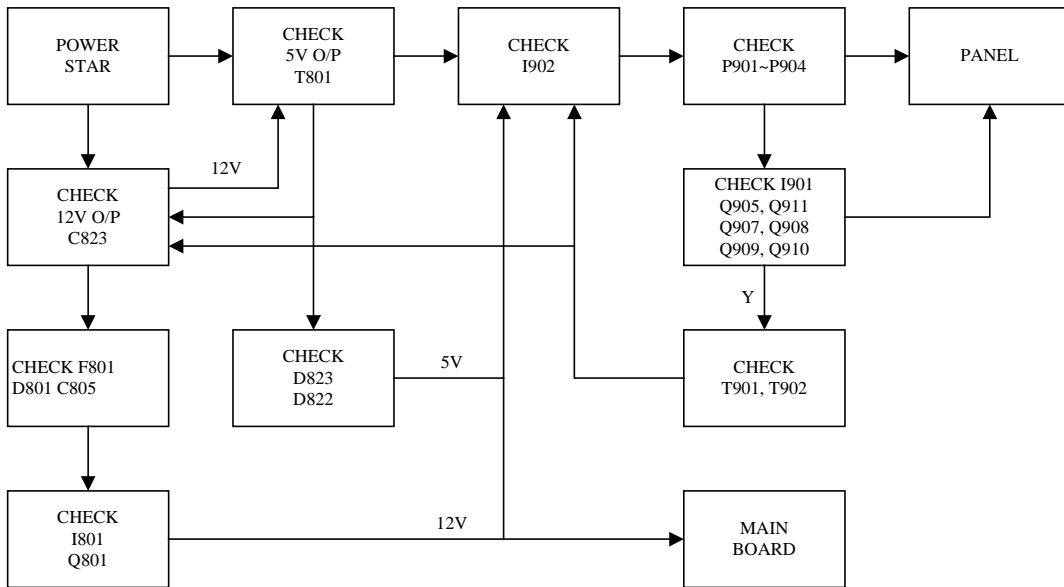

6.2. MCU NO FUNCTION

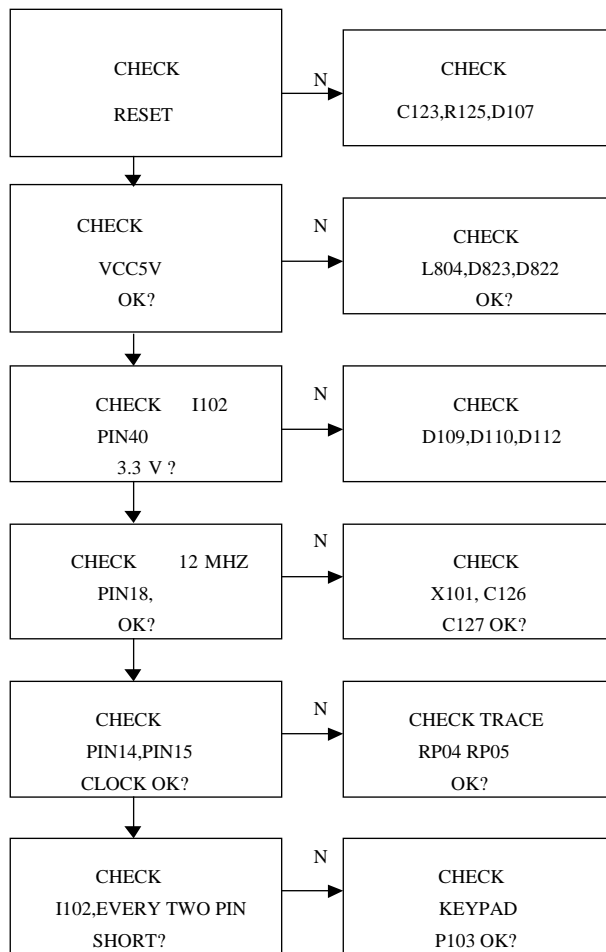

6.3. NO DISPLAY

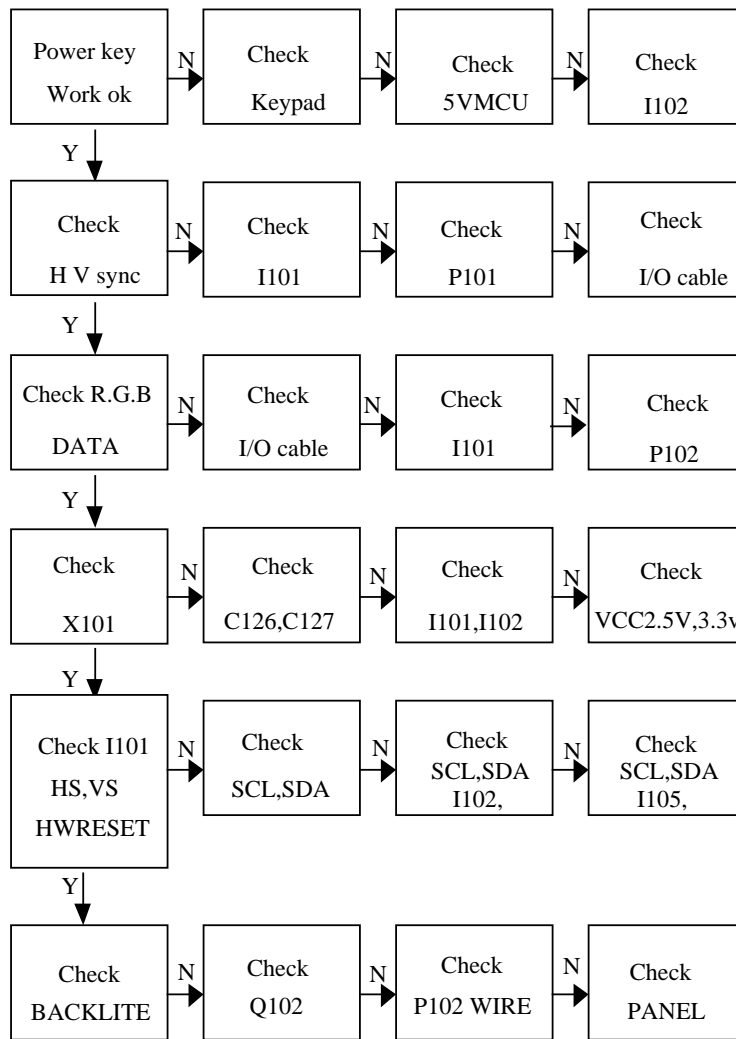

6.4. LOSE COLOR

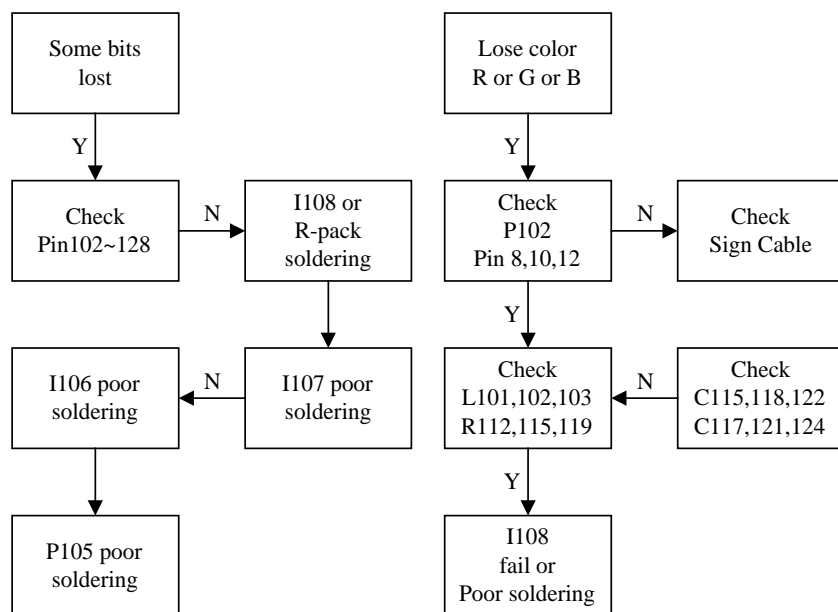

7. Recommended Spare Parts List

RECOMMENDED SPARE PARTS LIST (VA902-2)

ViewSonic Model Number: VS10715-2W

Rev: 1a

Serial No. Prefix: P4Q

Item	Description	ECR/ECN	ViewSonic P/N	Ref. P/N	Location	Universal number#	Q'ty
1	Accessories: AC POWER CORD USA WALL 1.83M BLACK		A-PC-0106-0121	2427130046P	P951		1
2	AC POWER CORD GERMAN WALL 1.83M BLACK		A-PC-0106-0138	2427130047P	P951		1
3	PC Board Assembly: PCB ASS'Y BLOCK (MAIN)		B-00004499	6201-7998909121			1
4	PCB ASS'Y BLOCK (CON)		B-00003004	6202-7998908101			1
5	Cabinets: BEZEL ASS'Y ABS 94HB PS-7604B VA902		C-00004500	2603307892			1
6	CABI BACK ASSY VE910 ABS 94HB BLACK 4001		C-00003008	2603407576			1
7	STAND VE910 ABS 94HB BLACK 4001		PL-00003006	2028259301P	5B01		1
8	DUST COVER ABS 94HB ELECTROPLATE AL		PL-00003034	2027260401P	5B20		1
9	Cables: I/O CABLE D15/C13 20276(4.5) 1.83M BLACK		CB-00003009	2427501191P	P961		1
10	Documentation: GUARANT CARD VIEWSONIC VA721/VE910 QSG		DC-00004478	2002310496P	6P84		1
11	CD-OWNER GUIDE VA902 WIZARD VS10715 AUO		DC-00004501	2438501231P	6P80		1
12	Electronic LCD PANEL M190EN03-V3 (N GRADE) AUO		E-00004502	2212009400P	V901 RB		1
13	Components: LCD PANEL M190EN03-V3 (A GRADE) AUO		E-00004503	2212009401P	V901 RA		1
14	Packing Material: CARTON BOX VA902 VS10715 TCO99 WORLD		P-00004504	2011133005P	6P01		1
15	POLYFOAM VE910-EPS (L)		P-00003014	2012179800P	6P20		1
16	POLYFOAM VE910 -EPS (R)		P-00003015	2012179900P	6P21		1

Remark 1: Above listed items are examples, supplier can expand the rows to add more necessary items.

Remark 2: All revised RSPLs with newly added items or any change made should be highlighted and correlated with the ECN/ECR approved by ViewSonic Corporation. This is to eliminate repeated cross checks of each item between this version and prior versions.

RECOMMENDED SPARE PARTS LIST (VA902b-2)

ViewSonic Model Number: VS10715-3W

Rev: 1a

Serial No. Prefix: Q4R

Item	Description	ECR/ECN	ViewSonic P/N	Ref.P/N	Location	Universal number#	Q'ty
1	Accessories: AC POWER CORD USA WALL 1.83M BLACK		A-PC-0106-0121	2427130046P	P951		1
2	Board Assembly: PCB ASS'Y BLOCK (MAIN)		B-00004499	6201-7998909121			1
3	PCB ASS'Y BLOCK (CON)		B-00003004	6202-7998908101			1
4	Cabinets: BEZEL ASS'Y ABS 94HB MIDNIGHT GRAY VA902B		C-00004811	2024268704P	1F01		1
5	CABI BACK ASSY VE910-B ABS 94HB MIDNIGHT GRAY		C-00003030	2022263502P	2C01		1
6	STAND VE910-B ABS 94HB MIDNIGHT GRAY		PL-00004517	2028259302P	5B01		1
7	DUST COVER ABS 94HB ELECTROPLATE AL		PL-00003034	2027260401P	5B20		1
8	Cables: I/O CABLE D15/C13 20276(4.5) 1.83M BLACK		CB-00003009	2427501191P	P961		1
9	Documentation: GUARANT CARD VIEWSONIC VA721/VE910 QSG		DC-00003455	2002310496P	6P84		1
10	CD-OWNER GUIDE VA902 WIZARD VS10715 AUO		DC-00004501	2438501231P	6P80		1
11	Electronic LCD PANEL M190EN03-V3 (N GRADE) AUO		E-00004502	2212009400P	V901 RB		1
12	Components: LCD PANEL M190EN03-V3 (A GRADE) AUO		E-00004503	2212009401P	V901 RA		1
13	Packing Material: CARTON BOX VA902B VS10715 TCO99 WORLD		P-00004812	2011133006P	6P01		1
14	POLYFOAM VE910-EPS (L)		P-00003014	2012179800P	6P20		1
15	POLYFOAM VE910 -EPS (R)		P-00003015	2012179900P	6P21		1

Remark 1: Above listed items are examples, supplier can expand the rows to add more necessary items.

Remark 2: All revised RSPLs with newly added items or any change made should be highlighted and correlated with the ECN/ECR approved by ViewSonic Corporation. This is to eliminate repeated cross checks of each item between this version and prior versions.

BOM LIST (VA902-2 for P-Region)

ViewSonic Model Number: VS10715-2W

Rev: 1a

Serial No. Prefix: P4Q

Item	ViewSonic P/N	Ref. P/N	Description	Location	Universal number#	Qty
1	#N/A	2024268703P	FRONT BEZEL ABS 94HB PS-7604B VA902	1F01		1
2	PL-00003024	2053754700P	LED INDIC.-PWR VE910 PMMA 94HB COLOR CLEAR	1F02		1
3	PL-00003025	2044267101P	FUNCTION KEY ABS 94HB ELECTROPLATE AL	1F03		1
4	M-MS-0808-9214	2051352100P	NAME PLATE VIEWSONIC E015-006 3-BIRD LOGO	1F04 RA		1
5	M-00003535	2051352101P	NAME PLATE VIEWSONIC 3-BIRD LOGO TNP	1F04 RB		1
6	#N/A	2051352800P	NAME PLATE 38.00MM*5.90MM	1F05		1
7	HW-00003026	2071974300P	METAL FITTG VE910 SECC T=0.8 FOR PANEL	1F10		1
8	M-SCW-0824-6715	2080002200P	SCREW,SPE L355 M3x6 DH NICKEL-PLATED	1F11		4
9	M-SCW-0824-0811	2080003700P	SCREW,SPE ISZZTER001A M3*6L MSWR17/FZMYI	1F12 1F13 1F16		9
10	HW-00003027	2071673800P	SHIELD PLATE VE910 ABS 94HB BLACK 4001	1F14		1
11	M-SCW-0824-6719	2082630062P	SCREW M3X6 P=0.5	1F15		2
12	M-00003862	2072460100P	INSULATOR 48*54*0.5T	1F17		1
13	#N/A	2072460200P	INSULATOR PC SHEET T=0.5 FR700 94V0	1F18		1
14	#N/A	2061455100P	BUSHING RUBBER CR BLACK 94HB	1F19		1
15	#N/A	2061455300P	BUSHING 10*15*7.5MM TAPE=T4000	1F20		1
16	HW-00003028	2071874300P	BRACKET,FIX SECC T=0.8 VE910 ACINLET	1F21		1
17	C-00003029	2022263501P	CABI BACK VE910 ABS 94HB BLACK 4001	2C01		1
18	M-MS-0808-9215	2051352200P	NAME PLATE VIEWSONIC E015-017	2C02		1
19	HW-00003031	2071872900P	BRACKET,FIX JT198QP SECC 0.8T WALL MOUNT	2C10		1
20	HW-00003032	2106657000P	HINGE VE910 -5'~+20'-90'	2C20		1
21	M-SCW-0824-0851	2082340072P	SCREW,CSK+ SCREW CSK+ M4*7	2C21		4
22	M-SCW-0824-0123	2084740102P	SCREW,BND T+ M4X10(BND T+)	2C22		1
23	M-SCW-0824-6944	2084740124P	SCREW,BND T+ M4X12(BND T+) (BLK)	2C23		2
24	M-SCW-0824-6746	2087340126P	SCREW,B SPW+ 4X12(+)SWRM-3 ZMC2-C	2C25		4
25	M-BK-0805-0070	2071869400P	BRACKET,FIX METAL PLATE 1.0MM KENSINGTON	2C30		1
26	M-MS-0808-9408	2061453400P	BUSHING VE710 PLUG RUBBER	2C50		4
27	PL-00003006	2028259301P	STAND VE910 ABS 94HB BLACK 4001	5B01		1
28	HW-00003033	2071974400P	METAL FITTG VE910 SECC T=1.5 FOR STAND	5B10		1
29	PL-PD-0714-0113	2039819301P	FOOT PAD RUBBER O20*2TMM SQUARE GRAIN	5B11		5
30	PL-00003034	2027260401P	DUST COVER ABS 94HB ELECTROPLATE AL	5B20		2
31	M-LB-0813-0769	2055613293P	LABEL VIEWSONIC OPEN STAND LABEL-LCD	5B30		1
32	P-00004504	2011133005P	CARTON BOX VA902 VS10715 TCO99 WORLD	6P01		1
33	#N/A	2055632184P	LABEL VA902 VS10715 (M) AUO	6P02		1
34	M-LB-0813-0855	2055613281P	LABEL VIEWSONIC VA520 NUMBER STICKER	6P03		1
35	#N/A	2055636046P	LABEL VA902 VS10715 SMALL LABEL	6P05		1
36	DC-00001586	2055613435P	LABEL VIEWSONIC INSET PAGE-1280X1024	6P06		1
37	M-LB-0813-0856	2055613379P	LABEL VIEWSONIC CONTAINER LABEL	6P11		0.21
38	M-LB-0813-0530	2055617101P	LABEL 10*20 HI-POT TESTED OK	6P13		1
39	M-LB-0813-0959	2055613392P	LABEL VSC HIGH VOLTAGE WARNING LABEL	6P14		1
40	P-00003014	2012179800P	POLYFOAM VE910-EPS (L)	6P20		1
41	P-00003015	2012179900P	POLYFOAM VE910 -EPS (R)	6P21		1
42	#N/A	2055134107P	LABEL VA902 VS10715 AUO TCO99	6P50		1
43	M-LB-0813-0528	2055103400P	LABEL JK0936F WEN	6P52		1
44	M-LB-0813-0002	2056603050P	SERIAL LABEL VIEWSONIC LCD SERIAL LABEL	6P55 6P54 6P51		3
45	M-MS-0808-1317	2013053000P	POLYETHY BAG 90CMX75CMX0.02t PE-LD	6P60		1
46	DC-00004501	2438501231P	CD-OWNER GUIDE VA902 WIZARD VS10715 AUO	6P80		1
47	DC-00004478	2002310496P	GUARANT CARD VIEWSONIC VA721/VE910 QSG	6P84		1
48	M-MS-0808-1316	2013222536P	POLYETHY BAG 250mmX350mmX0.3t ADD>PE-LD<	6P85		1
49	#N/A	2072253903P	HEAT SINK JT178DP SPTE T=1MM	9H01		1
50	#N/A	2072261500P	HEAT SINK JT178DP 40L*35W*20H AL T=3	9H02		1
51	#N/A	2072261401P	HEAT SINK JT178QP AL6063S-75 30*20*15	9H03		1
52	#N/A	2072261900P	HEAT SINK JT198QP SPTE 0.8t 18x11X43	9H04		1
53	#N/A	2105251400P	SPRING PLATE SPTE T=0.4MM (GROUND PLATE)	9H11 9H12 9H13		3
54	M-SCW-0824-0285	2084730082P	SCREW,BND T+ M3X8(BND T+)	9S01 9S02 9S03 5B12 2C40		10
55	E-C-0404-1841	2281447391P	CAP CER CC 0.047u/ 50V Y5V P=5.0 Z T	C101 C102 C103 C104 C105 C106 C110		7
56	E-C-0404-2980	2272133091P	CAP CER TC 33p/50V CH P=5.0 J T	C107		1
57	E-C-0404-1119	2272122191P	CAP CER TC 220p/50V CH P=5.0 J T	C108		1
58	E-C-0404-1815	2281410491P	CAP CER CC 0.1u/ 50V Y5V P=5.0 Z T	C109 C113 C114 C116 C118 C119 C121 C122 C125 C128		10
59	#N/A	2333347691P	CAP ELE 105°C EC 47u/ 16V 5*11 P=5.0 T	C112 C115 C117 C124		4
60	E-C-0404-2271	2333310791P	CAP ELE 105°C EC 100u/ 16V 6.3*11 P=5.0 T	C120 C141 C144		3
61	E-C-0404-1834	2333647591P	CAP ELE 105°C EC 4.7u/ 50V 5*11 P=5.0 T	C123 C815		2
62	E-C-0404-3092	2272110091P	CAP CER TC 10p/50V CH P=5.0 J T	C127 C146 C147		3
63	E-C-0404-1424	2333610591P	CAP ELE 105°C EC 1u/ 50V 5*11 P=5.0 T	C136		1
64	E-C-0404-1838	2333610691P	CAP ELE 105°C EC 10u/ 50V 5*11 P=5.0 T	C189 C809		2
65	#N/A	2300947401P	CAP,MTL MINI X2 0.47u/275V P=15.0 M C	C801 RA C801 RB		2
66	E-C-0404-1855	2287247212P	CAP CER Y2 4700p/250V Y5V P=10.0 M K	C802 C803 C831		3
67	#N/A	2357510708P	EC HI-RIPPLE 105C 400V EC 100u/400V 18*32 P=7.5 S	C805		1
68	E-C-0404-2262	2285110291P	CAP CER CC 1000P/1KV Y5P P=5.0 K T	C806		1
69	E-C-0404-4833	2281110491P	CAP CER CC 0.1u/50V (Y5P) P=5.0 K T	C807 C832 C845 C910 C917 C923 C925 C928		8
70	#N/A	2281118191P	CAP CER CC 180p/50V (Y5P) P=5.0 K T	C808		1
71	E-C-0404-1833	2333622691P	CAP ELE 105°C EC 22u/ 50V 5*11 P=5.0 T	C810		1
72	#N/A	2281168291P	CAP CER CC 6800pF/50V K T	C812		1
73	#N/A	2284122291P	CAP CER CC 2200pF/1KV P=5.0 K T	C820 C821		2
74	E-00003250	2330006601P	CAP ELE SPECIAL (3000HR) EC 1500u/ 16V 13*16 P=5.0 C	C822 RA		1
75	E-00003251	2330006701P	CAP ELE SPECIAL (3000HR) EC 1500u/ 16V 13*20 P=5.0 C	C822 RB		1
76	#N/A	2330006491P	CAP ELE SPECIAL EC 470u/ 16V 10*13 P=5.0 T	C823 C825 C906 C922		4
77	E-00003252	2330006501P	CAP ELE SPECIAL EC 1000u/ 10V 8*20 P=3.5 C	C824		1

Item	ViewSonic P/N	Ref. P/N	Description	Location	Universal number#	Q'ty
78	E-00003555	2302047291P	CAP,MTL MEF 4700pF/50V P=5.0 J T	C826		1
79	E-00003311	2302010491P	CAP,MTL MEF 0.1uF/50V P=5.0 J T	C901		1
80	#N/A	2275822001P	CAP CER TC 22pF/3KV CH J P=7.5 C	C902 C916		2
81	#N/A	2284010291P	CAP CER CC 1000p/50V X7R P=5.0 K T	C903 C904 C926 C927		4
82	#N/A	2275450901P	CAP CER TC 5P/3KV SL P=7.5 J C	C905 C918		2
83	#N/A	2284010391P	CAP CER CC 0.01u/50V X7R P=5.0 K T	C907 C921		2
84	#N/A	2302039291P	CAP,MTL MEF 3900pF/50V P=5.0 J T	C908 C909 C919 C920		4
85	#N/A	2302068391P	CAP,MTL MEF 0.068u/50V P=5.0 J T	C911 C924		2
86	E-C-0404-0287	2272147091P	CAP CER TC 47p/50V CH P=5.0 J T	C912		1
87	E-C-0404-3470	2272133191P	CAP CER TC 330p/50V CH P=5.0 J T	C913		1
88	#N/A	2302010391P	CAP,MTL MEF 0.01uF/50V P=5.0 J T	C914		1
89	#N/A	2333433691P	CAP ELE 105°C EC 33u/ 25V 5*11 P=5.0 T	C915		1
90	E-D-0403-0531	2363600195P	DIODE,SWITCH 1N4148 DO-35	D101 D102 D103 D104 D105 D106 D107 D108 D809 D813 D902 D905 D906 D907 D908 D910 D911 D913 D914 D915 D917 D919 D912 D918		24
91	#N/A	2363219095P	DIODE,RECT (EOL) 1N4002 DO-41 NI	D109 RA D110 RA		2
92	#N/A	2363234495P	DIODE,RECT 1N4002-FG DO-41 WILLAS	D109 RB D110 RB		2
93	#N/A	2363200895P	DIODE,RECT 1N4002 100V/1A DO-41 TSC	D109 RC D110 RC		2
94	#N/A	2363214695P	DIODE,RECT 1N4002F DO-41 FAGOR	D109 RD D110 RD		2
95	E-D-0403-1297	2363220895P	DIODE,RECT 11EQ04 NI	D112 RA		1
96	E-D-0403-1500	2363222195P	DIODE,RECT SB140 DO-41 PEC	D112 RB D909 D916		3
97	#N/A	2363703891P	LED 3 GRN/YEL	D701		1
98	#N/A	2368501800P	RECT,BRIDGE 2KBP06M 600V/2A PEC	D801		1
99	#N/A	2363231995P	DIODE,RECT UF4007 DO-41 1000V/1A PEC	D806 RA		1
100	#N/A	2363223195P	DIODE,RECT UF4007 DO-204AL GS	D806 RB		1
101	#N/A	2363230795P	DIODE,RECT 1H5G-TG-WS R-1 WILLAS	D807 RA		1
102	#N/A	2363601395P	DIODE,SWITCH 1U4G 400V/1A R-1 PEC	D807 RB		1
103	E-D-0403-0254	2363507995P	DIODE,ZENER MTZJ22B 20.64-21.71V ROHM	D808		1
104	E-D-0403-1532	2363505995P	DIODE,ZENER HZ12A2-TA-E DO-35 RENESAS	D810		1
105	#N/A	2363302800P	DIODE,SCHOTTKY SRF10120C ITO-220AB MOSPEC	D821		1
106	#N/A	2363220212P	DIODE,RECT 31DQ10FC NI	D822 D823		2
107	E-FS-0410-0009	2213125207P	FUSE 21502.5(2.5A) LITTEL	F801 RA		1
108	E-FS-0410-0102	2213125211P	FUSE FUSE 2.5A/250V SG501302.5 PICO	F801 RB		1
109	M-WR-0828-0478	2428106100P	JUMPER 0.6 *10.0mm	F901 J101 J110 J111 J116 J126 J802J903 J904 J906 J907 L801 R916 R935		14
110	#N/A	2365424900P	DIGITAL IC TSU16AS-LF SDIP-56 Mstar	I101		1
111	#N/A	2365500016P	MICRO-CONTROL IC MTV512GMN64 PDIP-40 MYSON	I102		1
112	#N/A	2365335086P	LINEAR IC AIC1117A-18PY SOT223 AIC	I103 RA		1
113	#N/A	2365335076P	LINEAR IC CM1117GDCM223 SOT223 CHAMPION	I103 RB		1
114	#N/A	2365813696P	IC,LINEAR(SMD) AP1117E18LA SOT-223 AnaChip	I103 RC		1
115	#N/A	2365335010P	LINEAR IC AP1084T33L TO-220 Anachip	I104 RA		1
116	#N/A	2365335020P	LINEAR IC AP1117T33L TO-220 Anachip	I104 RB		1
117	#N/A	2365335060P	LINEAR IC AIC1084-33PT TO-220 AIC	I104 RC		1
118	E-IC-0401-2269	2365915896P	IC,DIGITAL SMD 24LC16BT/SN SO-8 MICROCHIP	I105 RA		1
119	#N/A	2365100996P	MEMORY IC AT24C16AN-10SU-2.7 SO-8 AMTEL	I105 RB		1
120	#N/A	2365335056P	LINEAR IC LD7552-BS SOP-8 LEADTREND	I801		1
121	E-PC-0411-0083	2362401800P	PHOTO COUPLR TLP621 TOSHIBA	I802 RA		1
122	E-PC-0411-0082	2362401600P	PHOTO COUPLR (EOL) TLP721F(D4-GR) TOSHIBA	I802 RB		1
123	#N/A	2365328191P	LINEAR IC AP431VLA TO-92 ATC	I803 RA		1
124	E-IC-0401-1270	2365319391P	LINEAR IC TL431CLPRE3 TO-92 TI	I803 RB		1
125	E-IC-0401-2152	2365321991P	LINEAR IC KA431AZTA TO-92 FAIRCHILD	I803 RC		1
126	#N/A	2365327691P	LINEAR IC CM431GDCN TO-92 CHAMPION	I803 RD		1
127	#N/A	2365335046P	LINEAR IC OZ9932GN SOIC-8 O2-MICRO	I901		1
128	#N/A	2365330291P	LINEAR IC KA78L05AZ TO-92 FAIRCHILD	I902 RA		1
129	#N/A	2365330591P	LINEAR IC L78L05ACZ-A/P TO-92 ST	I902 RB		1
130	#N/A	2365330791P	LINEAR IC TS78L05CT TO-92 TSC	I902 RC		1
131	M-WR-0828-0450	2428106075P	JUMPER 0.6 *7.5mm	J102 J103 J105 J107 J112J113 J114 J115 J117 J118 J119 J120 J121 J122 J125 J127 J801 J803 J804 J901 J902 J905 J910 J915 J933		25
132	M-WR-0828-0460	2428106125P	JUMPER 6 *12.5mm	J106 J109 L901		3
133	M-MS-0808-0856	2428106200P	JUMPER 0.6 *20mm	J108		1
134	M-WR-0828-0455	2428106050P	JUMPER 6 *5.0mm	J123 J908 J909 L808		4
135	M-WR-0828-0451	2428106150P	JUMPER 0.6 *15.0mm	J124		1
136	#N/A	2434325603P	CU SHIELDING TAPE W25*L60mm (AL)	K901		1
137	E-L-0407-0013	2379101495P	FERRITE CORE 3.5*9*8.0	L102 L103 L104 L105 L802		5
138	#N/A	2371150903P	COIL,CHOKE 5uH 7.8*10 2UEW 0.65mm/12.5Ts	L803 L804		2
139	#N/A	2371145301P	COIL,CHOKE ET-20 45mH 2UEW 0.26mm/55+55Ts	L805		1
140	E-L-0407-0976	2379101491P	FERRITE CORE 3.5*9.0.8	L806		1
141	#N/A	2404371012P	CONNECTOR JST PH 13P TOP P=2.0 OR EQUAL	P101		1
142	#N/A	2404321230P	CONNECTOR CF10301D0T0 CVILUX	P102		1
143	#N/A	2404371007P	CONNECTOR JST PH 8P TOP P=2.0 OR EQUAL	P103		1
144	#N/A	2427408202P	WIRE HARNESS 8/8P H/B 1061#26 L=200mm P=2.0	P701		1
145	#N/A	2404380302P	CONNECTOR 87210-0236 P=3.5 ACE OR EQUAL	P901 P902 P903 P904		4
146	A-PC-0106-0121	2427130046P	AC POWER CORD USA WALL 1.83M BLACK	P951		1
147	CB-00003009	2427501191P	I/O CABLE D15/C13 20276(4.5) 1.83M BLACK	P961		1
148	#N/A	2420306301P	FFC CABLE FFC 30P*0.5mm*L80mm	P980		1
149	M-00003554	2097400301P	EYELET BSS3-1/2H T=0.25 SN 3uM	PG85 PG86 PG87		3

Item	ViewSonic P/N	Ref. P/N	Description	Location	Universal number#	Q'ty
150	E-Q-0402-0718	2361316191P	XISTOR,NPN R 2PC945P TO-92 PHILIPS	Q101 RA Q806 RA Q901 RA		3
151	E-Q-0402-0555	2361313691P	XISTOR,NPN R KSC945CGTA TO-92 FAIRCHILD	Q101 RB Q806 RB Q901 RB		3
152	E-Q-0402-0428	2361302591P	XISTOR,NPN R 2SC945-AP TO-92 NEC	Q101 RC Q806 RC Q901 RC		3
153	#N/A	2360501396P	FET,P-CH SMD AP2305GN SOT23 APEC	Q102 RA		1
154	#N/A	2360501296P	FET,P-CH SMD (EOL) AO3411 SOT-23 AOS	Q102 RB		1
155	E-Q-0402-1607	2360100596P	XISTOR,PNP R SMD MMBT3906-NL SOT23 FAIRCHILD	Q103 RA Q104 RA		2
156	E-Q-0402-1607	2360100796P	XISTOR,PNP R SMD MMBT3906 SOT23 DIODES	Q103 RB Q104 RB		2
157	#N/A	2360100696P	XISTOR,PNP R SMD PMBS3906 SOT-23 PHILIPS	Q103 RC Q104 RC		2
158	E-Q-0402-1375	2360100396P	XISTOR,PNP R SMD MMBT3906-7 SOT23 VISHAY	Q103 RD Q104 RD		2
159	#N/A	2360100896P	XISTOR,PNP R SMD MMBT3906LT1G SOT-23 ON	Q103 RE Q104 RE		2
160	#N/A	2361610900P	FET,N-CH AP04N70BF-H(LF) TO-220FM APEC	Q801 RA		1
161	E-00004445	2361611200P	FET,N-CH AP04N70BF-A(LF) TO-220FM APEC	Q801 RB		1
162	#N/A	2361410691P	XISTOR,NPN A MPS3904 SOT-54 PHILIPS	Q803		1
163	#N/A	2361210391P	XISTOR,PNP A MPS3906 SOT-54 PHILIPS	Q804 RA		1
164	#N/A	2361212191P	XISTOR,PNP A 2N3906TA TO-92 FAIRCHILD	Q804 RB		1
165	E-Q-0402-0720	2361111491P	XISTOR,PNP R 2PA733P TO-92 PHILIPS	Q805 RA		1
166	E-Q-0402-0962	2361110791P	XISTOR,PNP R KSA733-G TO-92 FAIRCHILD	Q805 RB		1
167	E-Q-0402-1106	2361100491P	XISTOR,PNP R 2SA733-AP-TP TO-92 NEC	Q805 RC		1
168	#N/A	2360609596P	FET,N-CH(SMD) AP9977GM SO-8 APEC	Q905 Q911		2
169	#N/A	2361609891P	FET,N-CH 2N7000TA TO-92 FAIRCHILD	Q907 Q908 Q909 Q910		4
170	E-R-0405-2776	2239207505P	RES,PRES 1/4 S RN 1/4WS 75.00 F T52 MINI	R101 R102 R103		3
171	E-R-0405-3216	2233447095P	RES,CBN 1/4 S RD 1/4WS 47 ohm J T52	R104 R105 R106 R107 R108 R109 R809 R853		8
172	E-R-0405-2367	2233422295P	RES,CBN 1/4 S RD 1/4WS 2.2Kohm J T52	R110 R112 R125 R837 R855		5
173	E-R-0405-3429	2233475095P	RES,CBN 1/4 S RD 1/4WS 75.00 J T52 MINI	R111		1
174	E-R-0405-1757	2233410195P	RES,CBN 1/4 S RD 1/4WS 100 ohm J T52	R113 R114 R115 R118		4
175	E-R-0405-3430	2233439195P	RES,CBN 1/4 S RD 1/4WS 390 ohm J T52	R116		1
176	E-R-0405-3214	2233410395P	RES,CBN 1/4 S RD 1/4WS 10Kohm J T52	R117 R127 R128 R32 R133 R135 R136 R162 R163 R908		10
177	E-R-0405-3211	2233447295P	RES,CBN 1/4 S RD 1/4WS 4.7Kohm J T52	R122 R123 R161		3
178	E-R-0405-0645	2233420195P	RES,CBN 1/4 S RD 1/4WS 200 ohm J T52	R124		1
179	E-R-0405-3213	2233410595P	RES,CBN 1/4 S RD 1/4WS 1.0Mohm J T52	R126 R918 R924 R934		4
180	E-R-0405-3215	2233447195P	RES,CBN 1/4 S RD 1/4WS 470 ohm J T52	R134 R137		2
181	E-R-0405-0078	2233456195P	RES,CBN 1/4 S RD 1/4WS 560 ohm J T52	R138		1
182	E-R-0405-6428	2235410903P	RES,MTL 1 RS 1W 1 ohm J P=15.0	R139		1
183	E-TH-0416-0042	2229201212P	THERMISTOR,PTH SCK-103 THINKING	R802		1
184	#N/A	2233491495P	RES,CBN 1/4 S RD 1/4WS 910Kohm J T52	R803 R812		2
185	#N/A	2239233235P	RES,PRES 1/4 S RN 1/4WS 332Kohm F T52	R804 R806 R843		3
186	#N/A	2239261935P	RES,PRES 1/4 S RN 1/4WS 619Kohm F T52	R805 R839 R844		3
187	#N/A	2233439095P	RES,CBN 1/4 S RD 1/4WS 39 ohm J T52	R807		1
188	#N/A	2239211035P	RES,PRES 1/4 S RN 1/4WS 110Kohm F T52	R808 R923		2
189	E-00003249	2236560476P	RES,MTL 2WS RS 2WS 0.604 ohm P=7.0 G	R811		1
190	E-R-0405-2306	2233433295P	RES,CBN 1/4 S RD 1/4WS 3.3Kohm J T52	R815 R842		2
191	#N/A	2235447913P	RES,MTL 1 RS 1WS 4.7ohm J P=12.5	R820		1
192	#N/A	2233610095P	RES,CBN 1/2WS RD 1/2WS 10 ohm J T52	R821		1
193	E-R-0405-3235	2233410295P	RES,CBN 1/4 S RD 1/4WS 1Kohm J T52	R823 R840 R845 R847		4
194	E-R-0405-2818	2239224325P	RES,PRES 1/4 S RN 1/4WS 24.3Kohm F T52	R824		1
195	#N/A	2239218215P	RES,PRES 1/4 S RN 1/4WS 1.82Kohm F T	R825		1
196	E-R-0405-0063	2233456295P	RES,CBN 1/4 S RD 1/4WS 5.6Kohm J T52	R826		1
197	#N/A	2239215815P	RES,PRES 1/4 S RN 1/4WS 1.58Kohm F T52	R828		1
198	E-R-0405-3034	2239210015P	RES,PRES 1/4 S RN 1/4WS 1Kohm F T52	R830		1
199	#N/A	2239291025P	RES,PRES 1/4 S RN 1/4WS 91.0Kohm F T52	R831 R926		2
200	E-R-0405-1171	2233482195P	RES,CBN 1/4 S RD 1/4WS 820 ohm J T52	R832 R846 R854		3
201	E-R-0405-3221	2233410495P	RES,CBN 1/4 S RD 1/4WS 100Kohm J T52	R833 R834 R835 R836		4
202	E-R-0405-4713	2233418295P	RES,CBN 1/4 S RD 1/4WS 1.8Kohm J T52	R841		1
203	E-R-0405-5980	2239210025P	RES,PRES 1/4 S RN 1/4WS 10Kohm F T	R851		1
204	#N/A	2242315595P	HIGH VOLTAGE RESISTOR RD 1/2W 1.5Mohm J T52	R905 R925		2
205	#N/A	2232410095P	RES,CBN 1/4 RD 1/4W 10 ohm J T	R906 R907 R911 R912		4
206	E-R-0405-4534	2239220015P	RES,PRES 1/4 S RN 1/4WS 2.0Kohm F T52	R909 R927		2
207	E-R-0405-3526	2233427195P	RES,CBN 1/4 S RD 1/4WS 270 ohm J T52	R913 R917		2
208	#N/A	2239245305P	RES,PRES 1/4 S RN 1/4WS 453 ohm F T	R914 R932		2
209	#N/A	2239278705P	RES,PRES 1/4 S RN 1/4WS 787 ohm F T	R919 R920 R936 R937		4
210	E-R-0405-6218	2233451295P	RES,CBN 1/4 S RD 1/4WS 5.1Kohm J T52	R921 R930		2
211	#N/A	2233451595P	RES,CBN 1/4 S RD 1/4WS 5.1Mohm J T	R922		1
212	#N/A	2239251125P	RES,PRES 1/4 S RN 1/4WS 51.1Kohm F T52	R929		1
213	#N/A	2259210308P	RES,CHIP NETWORKS 8P4R 1/16W 10Kohm J P=0.8	RP01 RP02 RP03		3
214	E-R-0405-6608	2259210108P	RES,CHIP NETWORKS 8P4R 1/16W 100 ohm J P=0.8	RP04 RP05		2
215	#N/A	2259227208P	RES,CHIP NETWORKS 8P4R 1/16W 2.7Kohm J P=0.8	RP06		1
216	E-R-0405-6007	2259247208P	RES,CHIP NETWORKS 8P4R 1/16W 4.7Kohm J P=0.8	RP07		1
217	#N/A	2403702513P	TACT SWITCH TSTA-2 4.3mm 160g HUA-JIE	S701 S702 S703 S704 S705		5
218	#N/A	2407413100P	SOCKET 0711-02-P10-9 INALWAYS	S801 RA		1
219	#N/A	2407413300P	SOCKET SC-8R-F15A9 SUPERCOM	S801 RB		1
220	#N/A	2407200991P	HOLDER,FUSE CQ-05T CONQUER	S802 RA S803 RA		2

Item	ViewSonic P/N	Ref. P/N	Description	Location	Universal number#	Q'ty
221	M-MS-0808-1313	2407200791P	HOLDER,FUSE FC-05C	S802 RB S803 RB		2
222	#N/A	2374228012P	XFORMER,POWR PT-003701-1 LAI-TAI	T801 RA		1
223	#N/A	2374228016P	XFORMER,POWR	T801 RB		1
224	#N/A	2374301000P	XFORMER INVERTER EEL-19 22/2000Ts 0.1*20/0.06mm	T901 T902		2
225	E-00003308	2202130701P	PC BOARD JT178QP4D M/B FR1 228*145 2.01	U101		1
226	#N/A	2202131400P	PC BOARD VE910 K/B FR1 120*23.5 V1.00	U701		1
227	E-00004502	2212009400P	LCD PANEL M190EN03-V3 (N GRADE) AUO	V901 RA		1
228	E-00004503	2212009401P	LCD PANEL M190EN03-V3 (A GRADE) AUO	V901 RB		1
229	E-X-0415-0119	2369103601P	XTAL,OSC 12.0000MHZ/49US 0.1mW/30pF	X101		1
230	#N/A	2363516895P	DIODE,ZENER HZ6B-2 5.6-5.9V DO-35 HITACHI	Z101 Z102 Z103 Z104 Z105		5

BOM LIST (VA902b-2)

ViewSonic Model Number: VS10715-3W

Rev: 1a

Serial No. Prefix: Q4R

Item	ViewSonic P/N	Ref. P/N	Description	Location	Universal number#	Q'ty
1	#N/A	2024268704P	FRONT BEZEL ABS 94HB MIDNIGHT GRAY VA902B	1F01		1
2	PL-00003024	2053754700P	LED INDIC.-PWR VE910 PMMA 94HB COLOR CLEAR	1F02		1
3	PL-00003025	2044267101P	FUNCTION KEY ABS 94HB ELECTROPLATE AL	1F03		1
4	M-MS-0808-9214	2051352100P	NAME PLATE VIEWSONIC E015-006 3-BIRD LOGO	1F04 RA		1
5	M-00003535	2051352101P	NAME PLATE VIEWSONIC 3-BIRD LOGO TNP	1F04 RB		1
6	#N/A	2051352800P	NAME PLATE 38.00MM*5.90MM	1F05		1
7	HW-00003026	2071974300P	METAL FITTG VE910 SECC T=0.8 FOR PANEL	1F10		1
8	M-SCW-0824-6715	2080002200P	SCREW,SPE L355 M3x6 DH NICKEL-PLATED	1F11		4
9	M-SCW-0824-0811	2080003700P	SCREW,SPE ISZZTER001A M3*6L MSWR17/FZMY1	1F12 1F13 1F16		9
10	HW-00003027	2071673800P	SHIELD PLATE VE910 SPTE T=0.3	1F14		1
11	M-SCW-0824-6719	2082630062P	SCREW M3X6 P=0.5	1F15		2
12	M-00003862	2072460100P	INSULATOR 48*54*0.5T	1F17		1
13	#N/A	2072460200P	INSULATOR PC SHEET T=0.5 FR700 94V0	1F18		1
14	#N/A	2061455100P	BUSHING RUBBER CR BLACK 94HB	1F19		1
15	#N/A	2061455300P	BUSHING 10*15*7.5MM TAPE=T4000	1F20		1
16	HW-00003028	2071874300P	BRACKET, FIX SECC T=0.8 VE910 ACINLET	1F21		1
17	C-00003030	2022263502P	CABI BACK VE910-B ABS 94HB MIDNIGHT GRAY	2C01		1
18	M-MS-0808-9396	2051352202P	NAME PLATE NAME PLATE VIEWSONIC E015-027	2C02		1
19	HW-00003031	2071872900P	BRACKET, FIX JT198QP SECC 0.8T WALL MOUNT	2C10		1
20	HW-00003032	2106657000P	HINGE VE910 -5'~+20'~90'	2C20		1
21	M-SCW-0824-0851	2082340072P	SCREW,CSK+ SCREW CSK+ M4*7	2C21		4
22	M-SCW-0824-0123	2084740102P	SCREW,BND T+ M4X10(BND T+)	2C22		1
23	M-SCW-0824-6944	2084740124P	SCREW,BND T+ M4X12(BND T+) (BLK)	2C23		2
24	M-SCW-0824-6746	2087340126P	SCREW,B SPW+ 4X12(+SWRM-3 ZMC2-C	2C25		4
25	M-BK-0805-0070	2071869400P	BRACKET, FIX METAL PLATE 1.0MM KENSINGTON	2C30		1
26	M-SCW-0824-0285	2084730082P	SCREW,BND T+ M3X8(BND T+)	2C40		2
27	M-MS-0808-9408	2061453400P	BUSHING VE710 PLUG RUBBER	2C50		4
28	PL-00004517	2028259302P	STAND VE910-B ABS 94HB MIDNIGHT GRAY	5B01		1
29	HW-00003033	2071974400P	METAL FITTG VE910 SECC T=1.5 FOR STAND	5B10		1
30	PL-PD-0714-0113	2039819301P	FOOT PAD RUBBER O20*2TMM SQUARE GRAIN	5B11		5
31	M-SCW-0824-0285	2084730082P	SCREW,BND T+ M3X8(BND T+)	5B12		5
32	PL-00003034	2027260401P	DUST COVER ABS 94HB ELECTROPLATE AL	5B20		2
33	M-LB-0813-0769	2055613293P	LABEL VIEWSONIC OPEN STAND LABEL-LCD	5B30		1
34	P-00004812	2011133006P	CARTON BOX VA902B VS10715 TCO99 WORLD	6P01		1
35	#N/A	2055632186P	LABEL VA902B VS10715(M) AUO	6P02		1
36	M-LB-0813-0855	2055613281P	LABEL VIEWSONIC VA520 NUMBER STICKER	6P03		1
37	#N/A	2055636047P	LABEL VA902B VS10715 SMALL LABEL	6P05		1
38	DC-00001586	2055613435P	LABEL VIEWSONIC INSET PAGE-1280X1024	6P06		1
39	M-LB-0813-0856	2055613379P	LABEL VIEWSONIC CONTAINER LABEL	6P11		1
40	M-LB-0813-0530	2055617101P	LABEL 10*20 HI-POT TESTED OK	6P13		1
41	M-LB-0813-0959	2055613392P	LABEL VSC HIGH VOLTAGE WARNING LABEL	6P14		1
42	P-00003014	2012179800P	POLYFOAM VE910-EPS (L)	6P20		1
43	P-00003015	2012179900P	POLYFOAM VE910-EPS (R)	6P21		1
44	#N/A	2055134109P	LABEL VA902B VS10715 AUO TCO99	6P50		1
45	M-LB-0813-0528	2055103400P	LABEL JK0936F WEN	6P52		1
46	M-LB-0813-0002	2056603050P	SERIAL LABEL VIEWSONIC LCD SERIAL LABEL	6P55 6P54 6P51		3
47	M-MS-0808-1317	2013053000P	POLYETHY BAG 90CMX75CMX0.02t PE-LD	6P60		1
48	DC-00004501	2438501231P	CD-OWNER GUIDE VA902 WIZARD VS10715 AUO	6P80		1
49	DC-00003455	2002310496P	GUARANT CARD VIEWSONIC VA721/VE910 QSG	6P84		1
50	M-MS-0808-1316	2013222536P	POLYETHY BAG 250mmX350mmX0.3t ADD>PE-LD<	6P85		1
51	#N/A	2072253903P	HEAT SINK JT178DP SPTE T=1MM	9H01		1
52	#N/A	2072261500P	HEAT SINK JT178DP 40L*35W*20H AL T=3	9H02		1
53	#N/A	2072261401P	HEAT SINK JT178QP AL6063S-75 30*20*15	9H03		1
54	#N/A	2072261900P	HEAT SINK JT198QP SPTE 0.8t 18x11X43	9H04		1
55	#N/A	2105251400P	SPRING PLATE SPTE T=0.4MM (GROUND PLATE)	9H11 9H12 9H13		3
56	M-SCW-0824-0285	2084730082P	SCREW,BND T+ M3X8(BND T+)	9S01 9S02 9S03 5B12		10
57	E-C-0404-1841	2281447391P	CAP CER CC 0.047u/ 50V Y5V P=5.0 Z T	C101 C102 C103 C104 C105 C106 C110		7
58	E-C-0404-2980	2272133091P	CAP CER TC 33p/50V CH P=5.0 J T	C107		1
59	E-C-0404-1119	2272122191P	CAP CER TC 220p/50V CH P=5.0 J T	C108		1
60	E-C-0404-1815	2281410491P	CAP CER CC 0.1u/ 50V Y5V P=5.0 Z T	C109 C113 C114 C116 C118 C119 C121 C122		10
61	#N/A	2333347691P	CAP ELE 105°C EC 47u/ 16V 5*11 P=5.0 T	C112 C115 C117 C124		4
62	E-C-0404-2271	2333310791P	CAP ELE 105°C EC 100u/ 16V 6.3*11 P=5.0 T	C120 C141 C144		3
63	E-C-0404-1834	2333647591P	CAP ELE 105°C EC 4.7u/ 50V 5*11 P=5.0 T	C123 C815		2
64	E-C-0404-3092	2272110091P	CAP CER TC 10p/50V CH P=5.0 J T	C127 C146 C147		3
65	E-C-0404-1424	2333610591P	CAP ELE 105°C EC 1u/ 50V 5*11 P=5.0 T	C136		1
66	E-C-0404-1838	2333610691P	CAP ELE 105°C EC 10u/ 50V 5*11 P=5.0 T	C189 C809		2
67	#N/A	2300947401P	CAP,MTL MINI X2 0.47u/275V P=15.0 M C	C801 RA C801 RB		2
68	E-C-0404-1855	2287247212P	CAP CER Y2 4700p/250V Y5V P=10.0 M K	C802 C803 C831		3
69	#N/A	2357510708P	EC HI-RIPPLE 105C 400V EC 100u/400V 18*32 P=7.5 S	C805		1
70	E-C-0404-2262	2285110291P	CAP CER CC 1000p/1KV Y5P P=5.0 K T	C806		1
71	E-C-0404-4833	2281110491P	CAP CER CC 0.1u/50V (Y5P) P=5.0 K T	C807 C832 C845 C910 C917 C923 C925 C928		8
72	#N/A	2281118191P	CAP CER CC 180p/50V (Y5P) P=5.0 K T	C808		1
73	E-C-0404-1833	2333622691P	CAP ELE 105°C EC 22u/ 50V 5*11 P=5.0 T	C810		1
74	#N/A	2281168291P	CAP CER CC 6800pF/50V K T	C812		1
75	#N/A	2284122291P	CAP CER CC 2200pF/1KV P=5.0 K T	C820 C821		2
76	E-00003250	2330006601P	CAP ELE SPECIAL (3000HR) EC 1500u/ 16V 13*16 P=5.0 C	C822 RA		1
77	E-00003251	2330006701P	CAP ELE SPECIAL (3000HR) EC 1500u/16V 13*20 P=5.0 C	C822 RB		1
78	#N/A	2330006491P	CAP ELE SPECIAL EC 470u/16V 10*13 P=5.0 T	C823 C825 C906 C922		4
79	E-00003252	2330006501P	CAP ELE SPECIAL EC 1000u/ 10V 8*20 P=3.5 C	C824		1
80	E-00003555	2302047291P	CAP,MTL MEF 4700pF/50V P=5.0 J T	C826		1
81	E-00003311	2302010491P	CAP,MTL MEF 0.1uF/50V P=5.0 J T	C901		1

Item	ViewSonic P/N	Ref. P/N	Description	Location	Universal number#	Q'ty
82	#N/A	2275822001P	CAP CER TC 22pF/3KV CH J P=7.5 C	C902 C916		2
83	#N/A	2284010291P	CAP CER CC 1000p/50V X7R P=5.0 K T	C903 C904 C926 C927		4
84	#N/A	2275450901P	CAP CER TC 5P/3KV SL P=7.5 J C	C905 C918		2
85	#N/A	2284010391P	CAP CER CC 0.01u/50V X7R P=5.0 K T	C907 C921		2
86	#N/A	2302039291P	CAP,MTL MEF 3900pF/50V P=5.0 J T	C908 C909 C919 C920		4
87	#N/A	2302068391P	CAP,MTL MEF 0.068u/50V P=5.0 J T	C911 C924		2
88	E-C-0404-0287	2272147091P	CAP CER TC 47p/50V CH P=5.0 J T	C912		1
89	E-C-0404-3470	2272133191P	CAP CER TC 330p/50V CH P=5.0 J T	C913		1
90	#N/A	2302010391P	CAP,MTL MEF 0.01uF/50V P=5.0 J T	C914		1
91	#N/A	2333433691P	CAP ELE 105°C EC 33u/ 25V 5*11 P=5.0 T	C915		1
92	E-D-0403-0531	2363600195P	DIODE,SWITCH 1N4148 DO-35	D101 D102 D103 D104 D105 D106 D107 D108 D809 D813 D902 D905 D906 D907 D908 D910 D911 D913 D914 D915		24
93	#N/A	2363219095P	DIODE,RECT (EOL) 1N4002 DO-41 NI	D109 RA D110 RA		2
94	#N/A	2363234495P	DIODE,RECT 1N4002-FG DO-41 WILLAS	D109 RB D110 RB		2
95	#N/A	2363200895P	DIODE,RECT 1N4002 100V/1A DO-41 TSC	D109 RC D110 RC		2
96	#N/A	2363214695P	DIODE,RECT 1N4002F DO-41 FAGOR	D109 RD D110 RD		2
97	E-D-0403-1297	2363220895P	DIODE,RECT 11EQ04 NI	D112 RA		1
98	E-D-0403-1500	2363222195P	DIODE,RECT SB140 DO-41 PEC	D112 RB D909 D916		3
99	#N/A	2363703891P	LED 3 GRN/YEL	D701		1
100	#N/A	2368501800P	RECT, BRIDGE 2KBP06M 600V/2A PEC	D801		1
101	#N/A	2363231995P	DIODE,RECT UF4007 DO-41 1000V/1A PEC	D806 RA		1
102	#N/A	2363223195P	DIODE,RECT UF4007 DO-204AL GS	D806 RB		1
103	#N/A	2363230795P	DIODE,RECT 1H5G-TG-WS R-1 WILLAS	D807 RA		1
104	#N/A	2363601395P	DIODE,SWITCH 1U4G 400V/1A R-1 PEC	D807 RB		1
105	E-D-0403-0254	2363507995P	DIODE,ZENER MTZJ22B 20.64-21.71V ROHM	D808		1
106	E-D-0403-1532	2363505995P	DIODE,ZENER HZ12A2-TA-E DO-35 RENESAS	D810		1
107	#N/A	2363302800P	DIODE,SCHOTTKY SRF10120C ITO-220AB MOSPEC	D821		1
108	#N/A	2363220212P	DIODE,RECT 31DQ10FC NI	D822 D823		2
109	E-FS-0410-0009	2213125207P	FUSE 21502.5(2.5A) LITTEL	F801 RA		1
110	E-FS-0410-0102	2213125211P	FUSE FUSE 2.5A/250V SG501302.5 PICO	F801 RB		1
111	M-WR-0828-0478	2428106100P	JUMPER 0.6 *10.0mm	F901 J101 J110 J111 J116 J126 J802 J903 J904 J906 J907 L801 R916		14
112	#N/A	2365424900P	DIGITAL IC TSU16AS-LF SDIP-56 Mstar	I101		1
113	#N/A	2365500016P	MICRO-CONTROL IC MTV512GMN64 PDIP-40 MYSON	I102		1
114	#N/A	2365335086P	LINEAR IC AIC1117A-18PY SOT223 AIC	I103 RA		1
115	#N/A	2365335076P	LINEAR IC CM1117GDCM223 SOT223 CHAMPION	I103 RB		1
116	#N/A	2365813696P	IC,LINEAR(SMD) AP1117E18LA SOT-223 AnaChip	I103 RC		1
117	#N/A	2365335010P	LINEAR IC AP1084T33L TO-220 Anachip	I104 RA		1
118	#N/A	2365335020P	LINEAR IC AP1117T33L TO-220 Anachip	I104 RB		1
119	#N/A	2365335060P	LINEAR IC AIC1084-33PT TO-220 AIC	I104 RC		1
120	E-IC-0401-2269	2365915896P	IC,DIGITAL SMD 24LC16BT/SN SO-8 MICROCHIP	I105 RA		1
121	#N/A	2365100996P	MEMORY IC AT24C16AN-10SU-2.7 SO-8 AMTEL	I105 RB		1
122	#N/A	2365335056P	LINEAR IC LD7552-BS SOP-8 LEADTREND	I801		1
123	E-PC-0411-0083	2362401800P	PHOTO COUPLR TLP621 TOSHIBA	I802 RA		1
124	E-PC-0411-0082	2362401600P	PHOTO COUPLR (EOL) TLP721F(D4-GR) TOSHIBA	I802 RB		1
125	#N/A	2365328191P	LINEAR IC AP431VLA TO-92 ATC	I803 RA		1
126	E-IC-0401-1270	2365319391P	LINEAR IC TL431CLPRE3 TO-92 TI	I803 RB		1
127	E-IC-0401-2152	2365321991P	LINEAR IC KA431AZTA TO-92 FAIRCHILD	I803 RC		1
128	#N/A	2365327691P	LINEAR IC CM431GDCN TO-92 CHAMPION	I803 RD		1
129	#N/A	2365335046P	LINEAR IC OZ9932GN SOIC-8 O2-MICRO	I901		1
130	#N/A	2365330291P	LINEAR IC KA78L05AZ TO-92 FAIRCHILD	I902 RA		1
131	#N/A	2365330591P	LINEAR IC L78L05ACZ-A/P TO-92 ST	I902 RB		1
132	#N/A	2365330791P	LINEAR IC TS78L05CT TO-92 TSC	I902 RC		1
133	M-WR-0828-0450	2428106075P	JUMPER 0.6 *7.5mm	J102 J103 J105 J107 J112 J113 J114 J115 J117 J118 J119 J120 J121 J122 J125 J127 J801 J803 J804 J901 J902		25
134	M-WR-0828-0460	2428106125P	JUMPER 6 *12.5mm	J106 J109 L901		3
135	M-MS-0808-0856	2428106200P	JUMPER 0.6 *20mm	J108		1
136	M-WR-0828-0455	2428106050P	JUMPER 6 *5.0mm	J123 J908 J909 L808		4
137	M-WR-0828-0451	2428106150P	JUMPER 0.6 *15.0mm	J124		1
138	#N/A	2434325603P	CU SHIELDING TAPE W25*L60mm (AL)	K901		1
139	E-L-0407-0013	2379101495P	FERRITE CORE 3.5*9*8.0	L102 L103 L104 L105		5
140	#N/A	2371150903P	COIL,CHOKE 5uH 7.8*10 2UEW 0.65mm/12.5Ts	L803 L804		2
141	#N/A	2371145301P	COIL,CHOKE ET-20 45mH 2UEW 0.26mm/55+55Ts	L805		1
142	E-L-0407-0976	2379101491P	FERRITE CORE 3.5*9.0.8	L806		1
143	#N/A	2404371012P	CONNECTOR JST PH 13P TOP P=2.0 OR EQUAL	P101		1
144	#N/A	2404321230P	CONNECTOR CF10301D0T0 CVILUX	P102		1
145	#N/A	2404371007P	CONNECTOR JST PH 8P TOP P=2.0 OR EQUAL	P103		1
146	#N/A	2427408202P	WIRE HARNESS 8/8P H/B 1061#26 L=200mm P=2.0	P701		1
147	#N/A	2404380302P	CONNECTOR 87210-0236 P=3.5 ACE OR EQUAL	P901 P902 P903 P904		4
148	A-PC-0106-0138	2427130047P	AC POWER CORD GERMAN WALL 1.83M BLACK	P951		1
149	CB-00003009	2427501191P	I/O CABLE D15/C13 20276(4.5) 1.83M BLACK	P961		1
150	#N/A	2420306301P	FFC CABLE FFC 30P*0.5mm*L80mm	P980		1
151	M-00003554	2097400301P	EYELET BSS3-1/2H T=0.25 SN 3uM	PG85 PG86 PG87		3
152	E-Q-0402-0718	2361316191P	XISTOR,NPN R 2PC945P TO-92 PHILIPS	Q101 RA Q806 RA Q901 RA		3

Item	ViewSonic P/N	Ref. P/N	Description	Location	Universal number#	Q'ty
153	E-Q-0402-0555	2361313691P	XISTOR,NPN R KSC945CGTA TO-92 FAIRCHILD	Q101 RB Q806 RB Q901 RB		3
154	E-Q-0402-0428	2361302591P	XISTOR,NPN R 2SC945-AP TO-92 NEC	Q101 RC Q806 RC Q901 RC		3
155	#N/A	2360501396P	FET,P-CH SMD AP2305GN SOT23 APEC	Q102 RA		1
156	#N/A	2360501296P	FET,P-CH SMD (EOL) AO3411 SOT-23 AOS	Q102 RB		1
157	E-Q-0402-1607	2360100596P	XISTOR,PNP R SMD MMBT3906-NL SOT23 FAIRCHILD	Q103 RA Q104 RA		2
158	E-Q-0402-1607	2360100796P	XISTOR,PNP R SMD MMBT3906 SOT23 DIODES	Q103 RB Q104 RB		2
159	#N/A	2360100696P	XISTOR,PNP R SMD PMBS3906 SOT-23 PHILIPS	Q103 RC Q104 RC		2
160	E-Q-0402-1375	2360100396P	XISTOR,PNP R SMD MMBT3906-7 SOT23 VISHAY	Q103 RD Q104 RD		2
161	#N/A	2360100896P	XISTOR,PNP R SMD MMBT3906LT1G SOT-23 ON	Q103 RE Q104 RE		2
162	#N/A	2361610900P	FET,N-CH AP04N70BF-H(LF) TO-220FM APEC	Q801 RA		1
163	E-00004445	2361611200P	FET,N-CH AP04N70BF-A(LF) TO-220FM APEC	Q801 RB		1
164	#N/A	2361410691P	XISTOR,NPN A MPS3904 SOT-54 PHILIPS	Q803		1
165	#N/A	2361210391P	XISTOR,PNP A MPS3906 SOT-54 PHILIPS	Q804 RA		1
166	#N/A	2361212191P	XISTOR,PNP A 2N3906TA TO-92 FAIRCHILD	Q804 RB		1
167	E-Q-0402-0720	2361111491P	XISTOR,PNP R 2PA733P TO-92 PHILIPS	Q805 RA		1
168	E-Q-0402-0962	2361110791P	XISTOR,PNP R KSA733-G TO-92 FAIRCHILD	Q805 RB		1
169	E-Q-0402-1106	2361100491P	XISTOR,PNP R 2SA733-AP-TP TO-92 NEC	Q805 RC		1
170	#N/A	2360609596P	FET,N-CH(SMD) AP9977GM SO-8 APEC	Q905 Q911		2
171	#N/A	2361609891P	FET,N-CH 2N7000TA TO-92 FAIRCHILD	Q907 Q908 Q909 Q910		4
172	E-R-0405-2776	2239207505P	RES,PRE 1/4 S RN 1/4WS 75.00 F T52 MINI	R101 R102 R103		3
173	E-R-0405-3216	2233447095P	RES,CBN 1/4 S RD 1/4WS 47 ohm J T52	R104 R105 R106 R107 R108 R109 R809 R853		8
174	E-R-0405-2367	2233422295P	RES,CBN 1/4 S RD 1/4WS 2.2Kohm J T52	R110 R112 R125 R837		5
175	E-R-0405-3429	2233475095P	RES,CBN 1/4 S RD 1/4WS 75.00 J T52 MINI	R111		1
176	E-R-0405-1757	2233410195P	RES,CBN 1/4 S RD 1/4WS 100 ohm J T52	R113 R114 R115 R118		4
177	E-R-0405-3430	2233439195P	RES,CBN 1/4 S RD 1/4WS 390 ohm J T52	R116		1
178	E-R-0405-3214	2233410395P	RES,CBN 1/4 S RD 1/4WS 10Kohm J T52	R117 R127 R128 R32 R133 R135 R136 R162		10
179	E-R-0405-3211	2233447295P	RES,CBN 1/4 S RD 1/4WS 4.7Kohm J T52	R122 R123 R161		3
180	E-R-0405-0645	2233420195P	RES,CBN 1/4 S RD 1/4WS 200 ohm J T52	R124		1
181	E-R-0405-3213	2233410595P	RES,CBN 1/4 S RD 1/4WS 1.0Mohm J T52	R126 R918 R924 R934		4
182	E-R-0405-3215	2233447195P	RES,CBN 1/4 S RD 1/4WS 470 ohm J T52	R134 R137		2
183	E-R-0405-0078	2233456195P	RES,CBN 1/4 S RD 1/4WS 560 ohm J T52	R138		1
184	E-R-0405-6428	2235410903P	RES,MTL 1 RS 1W 1 ohm J P=15.0	R139		1
185	E-TH-0416-0042	2229201212P	THERMISTOR,PTH SCK-103 THINKING	R802		1
186	#N/A	2233491495P	RES,CBN 1/4 S RD 1/4WS 910Kohm J T52	R803 R812		2
187	#N/A	2239233235P	RES,PRE 1/4 S RN 1/4WS 332Kohm F T52	R804 R806 R843		3
188	#N/A	2239261935P	RES,PRE 1/4 S RN 1/4WS 619Kohm F T52	R805 R839 R844		3
189	#N/A	2233439095P	RES,CBN 1/4 S RD 1/4WS 39 ohm J T52	R807		1
190	#N/A	2239211035P	RES,PRE 1/4 S RN 1/4WS 110Kohm F T52	R808 R923		2
191	E-00003249	2236560476P	RES MTL 2WS RS 2WS 0.604 ohm P=7.0 G	R811		1
192	E-R-0405-2306	2233433295P	RES,CBN 1/4 S RD 1/4WS 3.3Kohm J T52	R815 R842		2
193	#N/A	2235447913P	RES,MTL 1 RS 1WS 4.7ohm J P=12.5	R820		1
194	#N/A	2233610095P	RES,CBN 1/2WS RD 1/2WS 10 ohm J T52	R821		1
195	E-R-0405-3235	2233410295P	RES,CBN 1/4 S RD 1/4WS 1Kohm J T52	R823 R840 R845 R847		4
196	E-R-0405-2818	2239224325P	RES,PRE 1/4 S RN 1/4WS 24.3Kohm F T52	R824		1
197	#N/A	2239218215P	RES,PRE 1/4 S RN 1/4WS 1.82Kohm F T	R825		1
198	E-R-0405-0063	2233456295P	RES,CBN 1/4 S RD 1/4WS 5.6Kohm J T52	R826		1
199	#N/A	2239215815P	RES,PRE 1/4 S RN 1/4WS 1.58Kohm F T52	R828		1
200	E-R-0405-3034	2239210015P	RES,PRE 1/4 S RN 1/4WS 1Kohm F T52	R830		1
201	#N/A	2239291025P	RES,PRE 1/4 S RN 1/4WS 91.0Kohm F T52	R831 R926		2
202	E-R-0405-1171	2233482195P	RES,CBN 1/4 S RD 1/4WS 820 ohm J T52	R832 R846 R854		3
203	E-R-0405-3221	2233410495P	RES,CBN 1/4 S RD 1/4WS 100Kohm J T52	R833 R834 R835 R836		4
204	E-R-0405-4713	2233418295P	RES,CBN 1/4 S RD 1/4WS 1.8Kohm J T52	R841		1
205	E-R-0405-5980	2239210025P	RES,PRE 1/4 S RN 1/4WS 10Kohm F T	R851		1
206	#N/A	2242315595P	HIGH VOLTAGE RESISTOR RD 1/2W 1.5Mohm J T52	R905 R925		2
207	#N/A	2232410095P	RES,CBN 1/4 RD 1/4W 10 ohm J T	R906 R907 R911 R912		4
208	E-R-0405-4534	2239220015P	RES,PRE 1/4 S RN 1/4WS 2.0Kohm F T52	R909 R927		2
209	E-R-0405-3526	2233427195P	RES,CBN 1/4 S RD 1/4WS 270 ohm J T52	R913 R917		2
210	#N/A	2239245305P	RES,PRE 1/4 S RN 1/4WS 453 ohm F T	R914 R932		2
211	#N/A	2239278705P	RES,PRE 1/4 S RN 1/4WS 787 ohm F T	R919 R920 R936 R937		4
212	E-R-0405-6218	2233451295P	RES,CBN 1/4 S RD 1/4WS 5.1Kohm J T52	R921 R930		2
213	#N/A	2233451595P	RES,CBN 1/4 S RD 1/4WS 5.1Mohm J T	R922		1
214	#N/A	2239251125P	RES,PRE 1/4 S RN 1/4WS 51.1Kohm F T52	R929		1
215	#N/A	2259210308P	RES,CHIP NETWORKS 8P4R 1/16W 10Kohm J P=0.8	RP01 RP02 RP03		3
216	E-R-0405-6608	2259210108P	RES,CHIP NETWORKS 8P4R 1/16W 100 ohm J P=0.8	RP04 RP05		2
217	#N/A	2259227208P	RES,CHIP NETWORKS 8P4R 1/16W 2.7Kohm J P=0.8	RP06		1
218	E-R-0405-6007	2259247208P	RES,CHIP NETWORKS 8P4R 1/16W 4.7Kohm J P=0.8	RP07		1
219	#N/A	2403702513P	TACT SWITCH TSTA-2 4.3mm 160g HUA-JIE	S701 S702 S703 S704		5
220	#N/A	2407413100P	SOCKET 0711-02-PI0-9 INALWAYS	S801 RA		1
221	#N/A	2407413300P	SOCKET SC-8R-F15A9 SUPERCOM	S801 RB		1
222	#N/A	2407200991P	HOLDER,FUSE CQ-05T CONQUER	S802 RA S803 RA		2
223	M-MS-0808-1313	2407200791P	HOLDER,FUSE FC-05C	S802 RB S803 RB		2
224	#N/A	2374228012P	XFORMER,POWR PT-003701-1 LAI-TAI	T801 RA		1
225	#N/A	2374228016P	XFORMER,POWR	T801 RB		1
226	#N/A	2374301000P	XFORMER INVERTER EEL-19 22/2000Ts 0.1*20/0.06mm	T901 T902		2
227	E-00003308	2202130701P	PC BOARD JT178QP4D M/B FR1 228*145 2.01	U101		1
228	#N/A	2202131400P	PC BOARD VE910 K/B FR1 120*23.5 V1.00	U701		1
229	E-00004502	2212009400P	LCD PANEL M190EN03-V3 (N GRADE) AUO	V901 RA		1

Item	ViewSonic P/N	Ref. P/N	Description	Location	Universal number#	Q'ty
230	E-00004503	2212009401P	LCD PANEL M190EN03-V3 (A GRADE) AUO	V901 RB		1
231	E-X-0415-0119	2369103601P	XTAL,OSC 12.0000MHZ/49US 0.1mW/30pF	X101		1
232	#N/A	2363516895P	DIODE,ZENER HZ6B-2 5.6-5.9V DO-35 HITACHI	Z101 Z102 Z103 Z104		5

8. Exploded View And Exploded Parts List

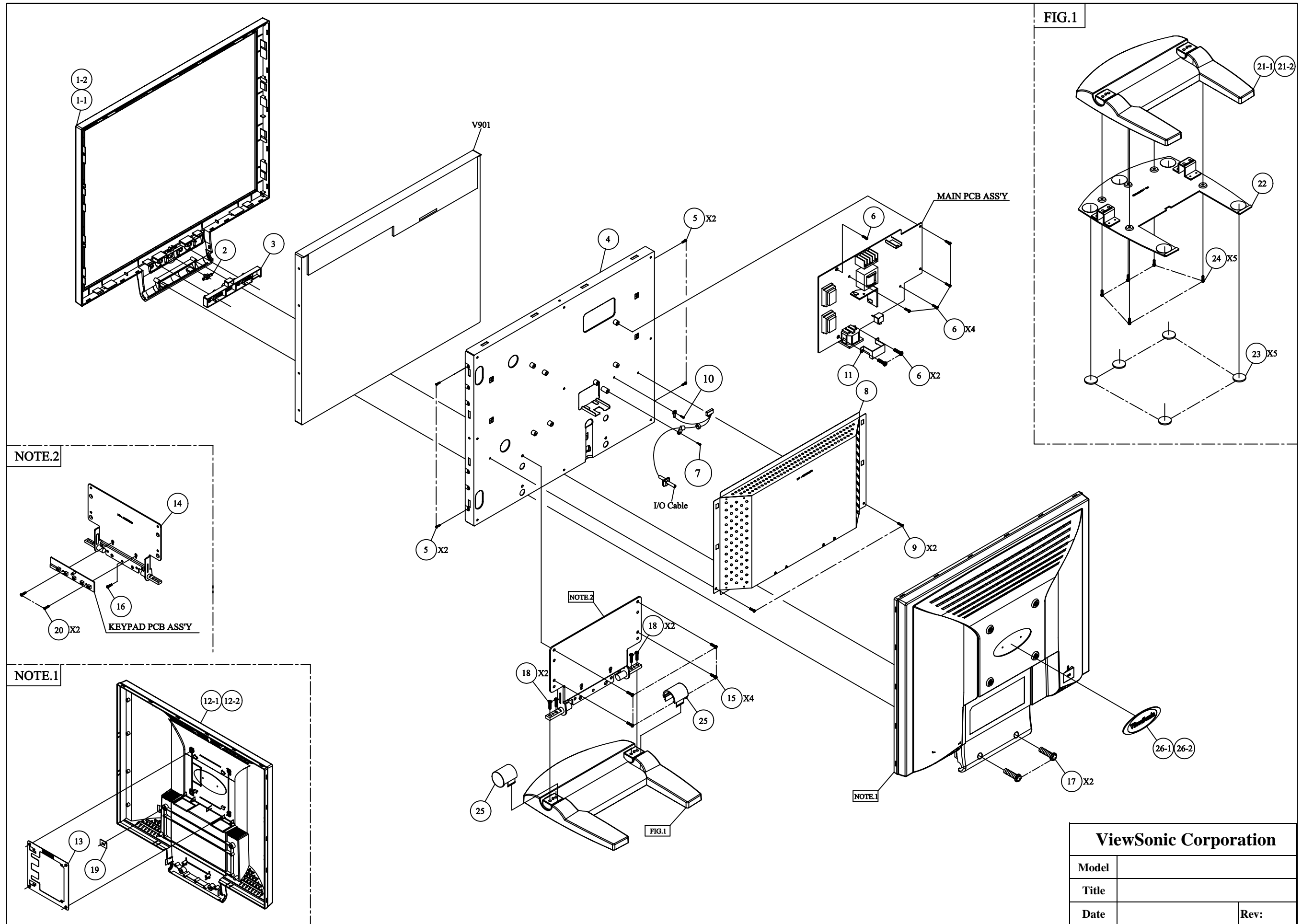

EXPLODED PARTS LIST (VA902/b-2)

ViewSonic Model Number: VS10715-2W/3W

Rev: 1a

Serial No. Prefix: P4Q

Item	ViewSonic P/N	Ref. P/N	Description		Q'ty
1-1	#N/A	2024268703P	FRONT BEZEL	ABS 94HB PS-7604B VA902	1
1-2	#N/A	2024268704P	FRONT BEZEL	ABS 94HB MIDNIGHT GRAY VA902B	1
2	PL-00003024	2053754700P	LED INDIC.-PWR	VE910 PMMA 94HB COLOR CLEAR	1
3	PL-00003025	2044267101P	FUNCTION KEY	ABS 94HB ELECTROPLATE AL	1
4	HW-00003026	2071974300P	METAL FITTG	VE910 SECC T=0.8 FOR PANEL	1
5	M-SCW-0824-6715	2080002200P	SCREW,SPE	L355 M3x6 DH NICKEL-PLATED	4
6	M-SCW-0824-0811	2080003700P	SCREW,SPE	ISZZTER001A M3*6L MSWR17/FZMYI	7
7	M-SCW-0824-0811	2080003700P	SCREW,SPE	ISZZTER001A M3*6L MSWR17/FZMYI	1
8	HW-00003027	2071673800P	SHIELD PLATE	VE910 SPTT T=0.3	1
9	M-SCW-0824-6719	2082630062P	SCREW	M3X6 P=0.5	2
10	M-SCW-0824-0811	2080003700P	SCREW,SPE	ISZZTER001A M3*6L MSWR17/FZMYI	1
11	HW-00003028	2071874300P	BRACKET,FIX	SECC T=0.8 VE910 ACINLET	1
12-1	C-00003029	2022263501P	CABI BACK	VE910 ABS 94HB BLACK 4001	1
12-2	C-00003030	2022263502P	CABI BACK	VE910-B ABS 94HB MIDNIGHT GRAY	1
13	HW-00003031	2071872900P	BRACKET,FIX	JT198QP SECC 0.8T WALL MOUNT	1
14	HW-00003032	2106657000P	HINGE	VE910 -5'~+20'~90'	1
15	M-SCW-0824-0851	2082340072P	SCREW,CSK+	SCREW CSK+ M4*7	4
16	M-SCW-0824-0123	2084740102P	SCREW,BND T+	M4X10(BND T+)	1
17	M-SCW-0824-6944	2084740124P	SCREW,BND T+	M4X12(BND T+) (BLK)	2
18	M-SCW-0824-6746	2087340126P	SCREW,B SPW+	4X12(+)SWRM-3 ZMC2-C	4
19	M-BK-0805-0070	2071869400P	BRACKET,FIX	METAL PLATE 1.0MM KENSINGTON	1
20	M-SCW-0824-0285	2084730082P	SCREW,BND T+	M3X8(BND T+)	2
21-1	PL-00003006	2028259301P	STAND	VE910 ABS 94HB BLACK 4001	1
21-2	PL-00003016	2028259302P	STAND	VE910-B ABS 94HB MIDNIGHT GRAY	1
22	HW-00003033	2071974400P	METAL FITTG	VE910 SECC T=1.5 FOR STAND	1
23	PL-PD-0714-0113	2039819301P	FOOT PAD	RUBBER O20*2TMM SQUARE GRAIN	5
24	M-SCW-0824-0285	2084730082P	SCREW,BND T+	M3X8(BND T+)	5
25	PL-00003034	2027260401P	DUST COVER	ABS 94HB ELECTROPLATE AL	2
26-1	M-MS-0808-9215	2051352200P	NAME PLATE	VIEWSONIC E015-017	1
26-2	M-MS-0808-9396	2051352202P	NAME PLATE	VIEWSONIC E015-027	1
27	#N/A	2427408202P	WIRE HARNESS	8/8P H/B 1061#26 L=200mm P=2.0	1
28	#N/A	2420306301P	FFC CABLE	FFC 30P*0.5mm*L80mm	1

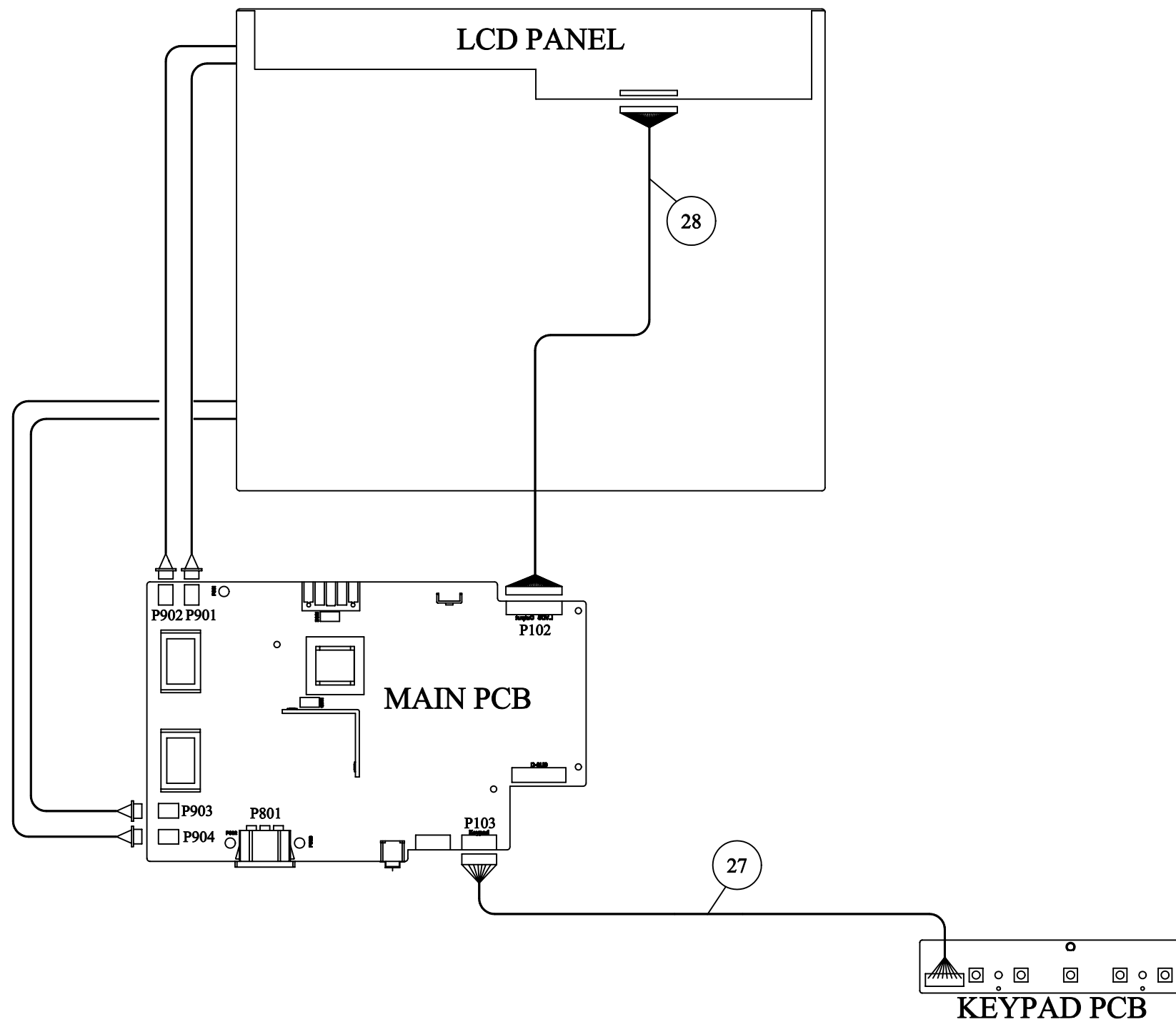

ViewSonic Corporation	
Model	
Title	
Date	Rev:

9. Block Diagram

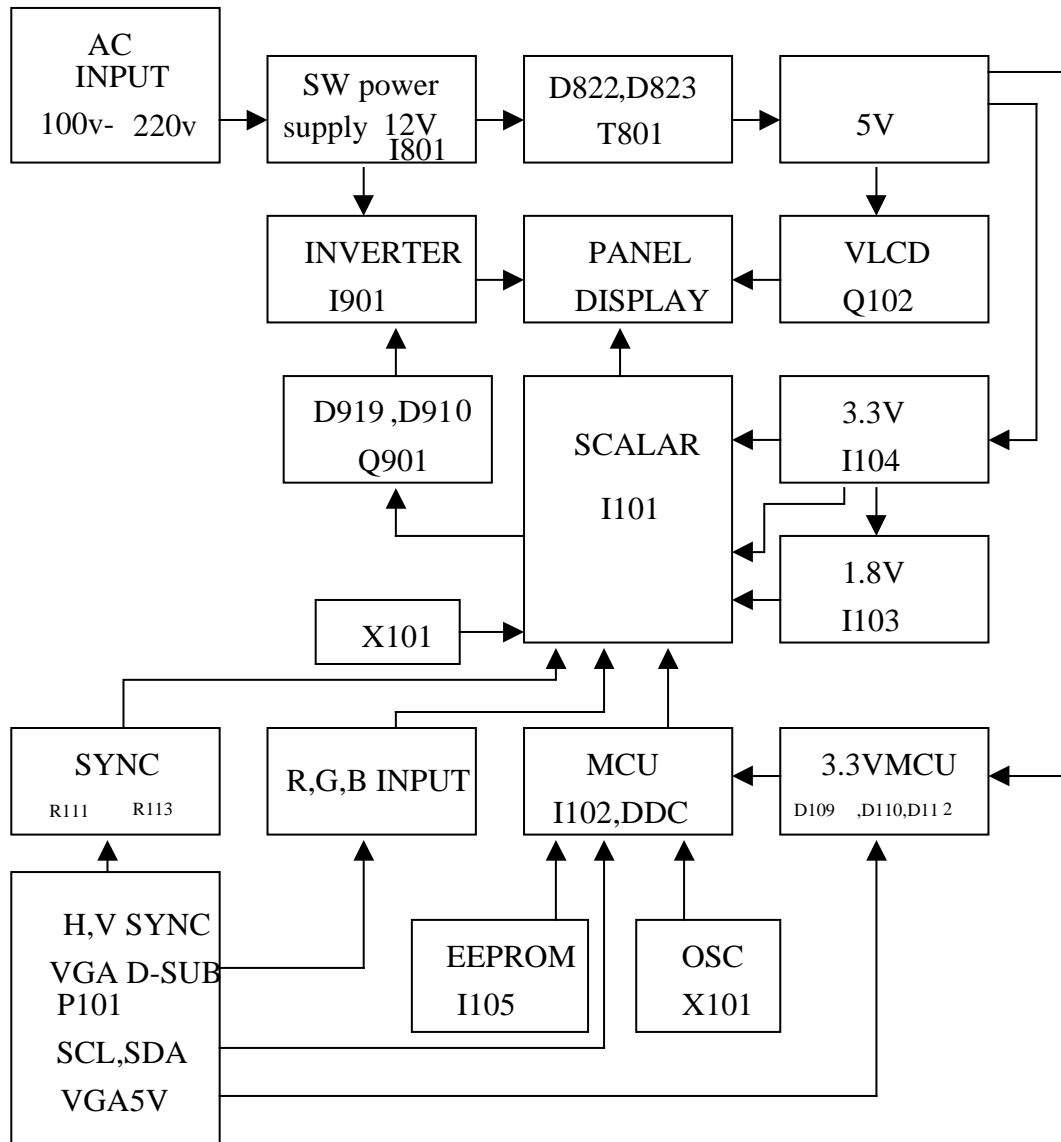

10. Schematic Diagrams (VA902/b-2)

10.1. DC - DC

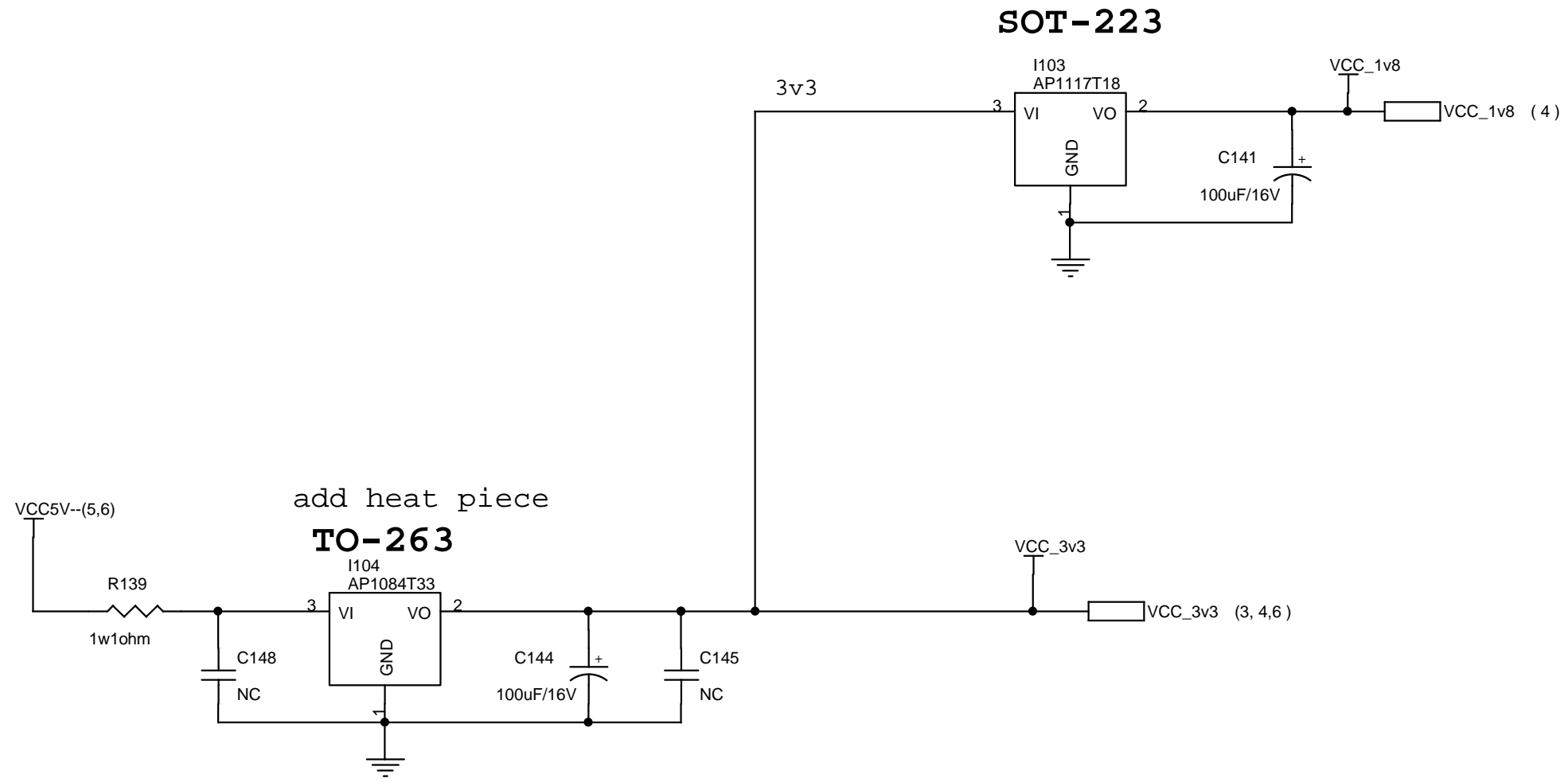

ViewSonic Corporation	
Model	DC
Title	
Date	Rev:

10.2. VGA INPUT

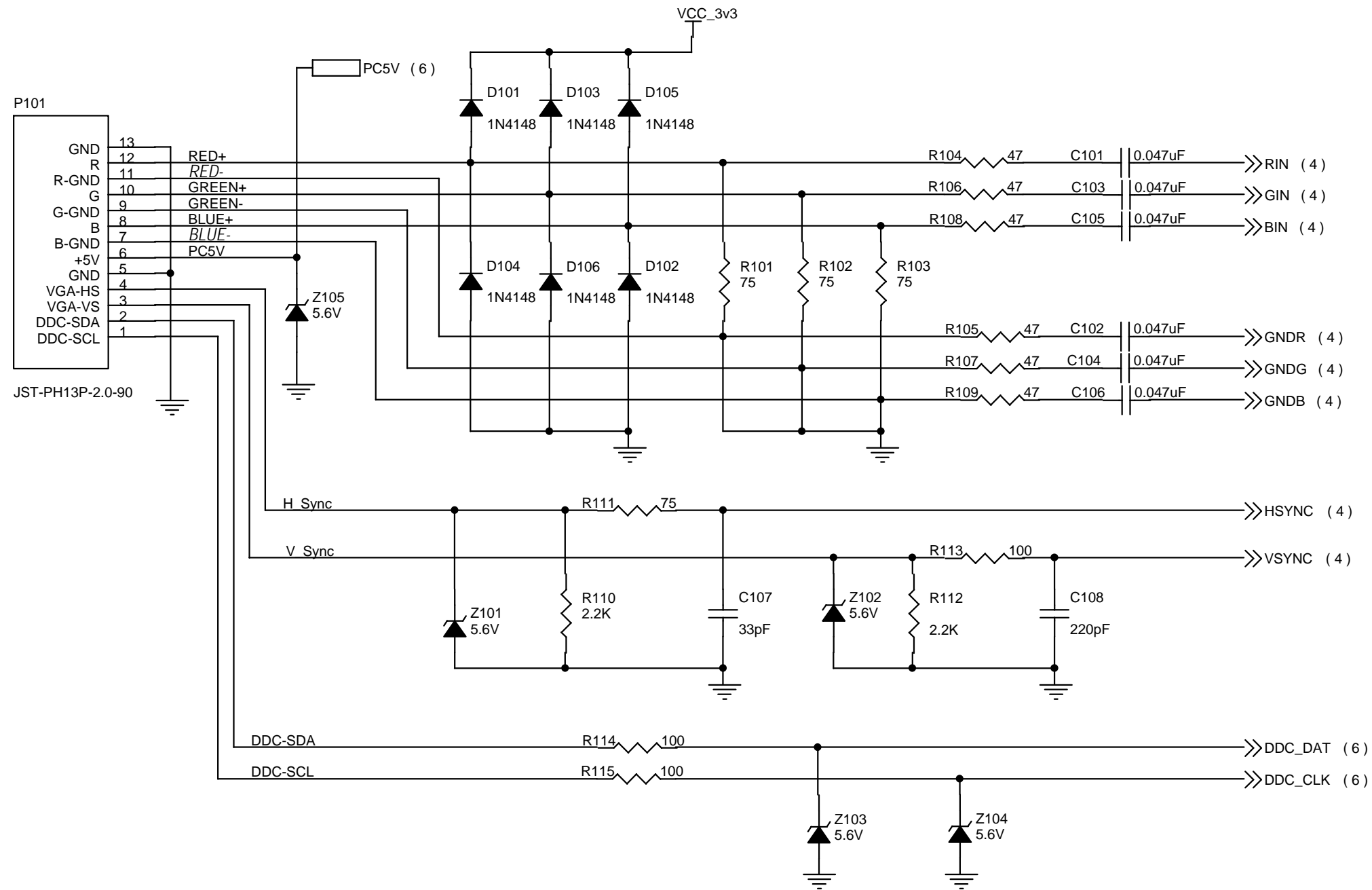

ViewSonic Corporation	
Model	VGA
Title	
Date	Rev:

10.3. SCALER

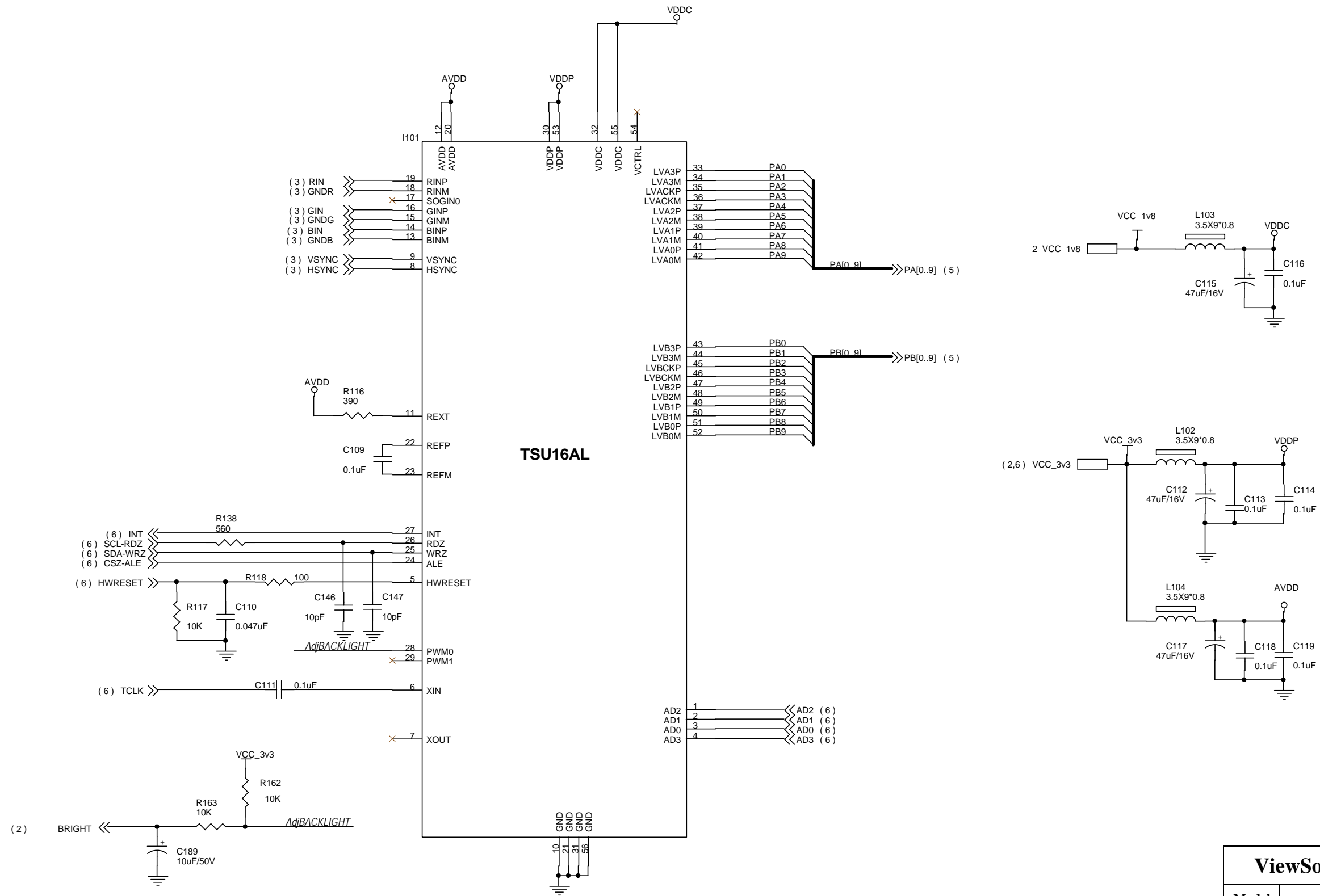

ViewSonic Corporation	
Model	SCALER
Title	
Date	Rev:

10.4. PANEL INTERFACE

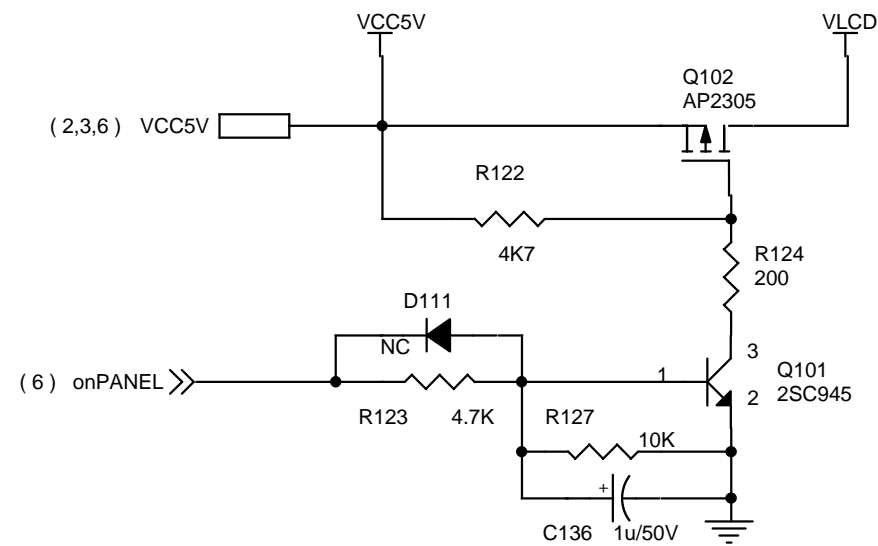
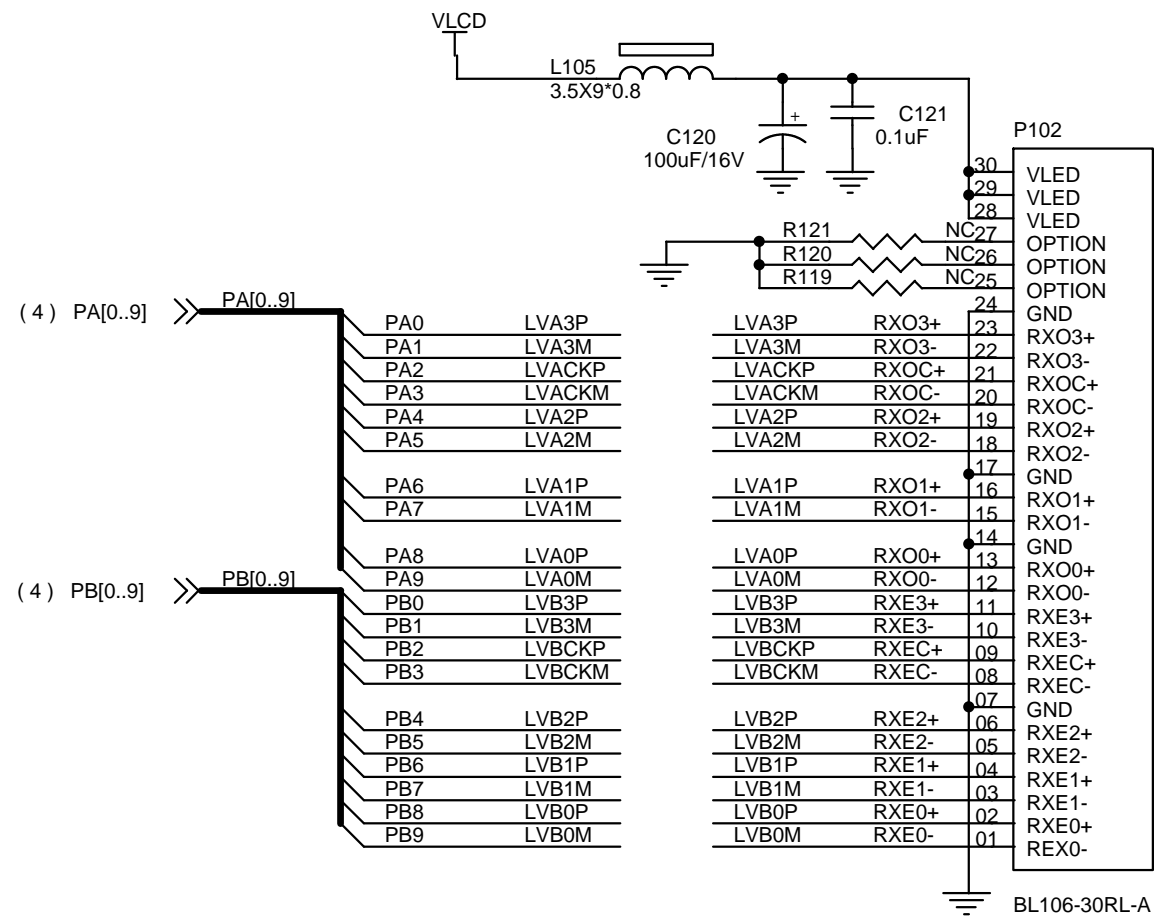

ViewSonic Corporation

Model	RTD2523
Title	
Date	Rev:

10.5. MCU

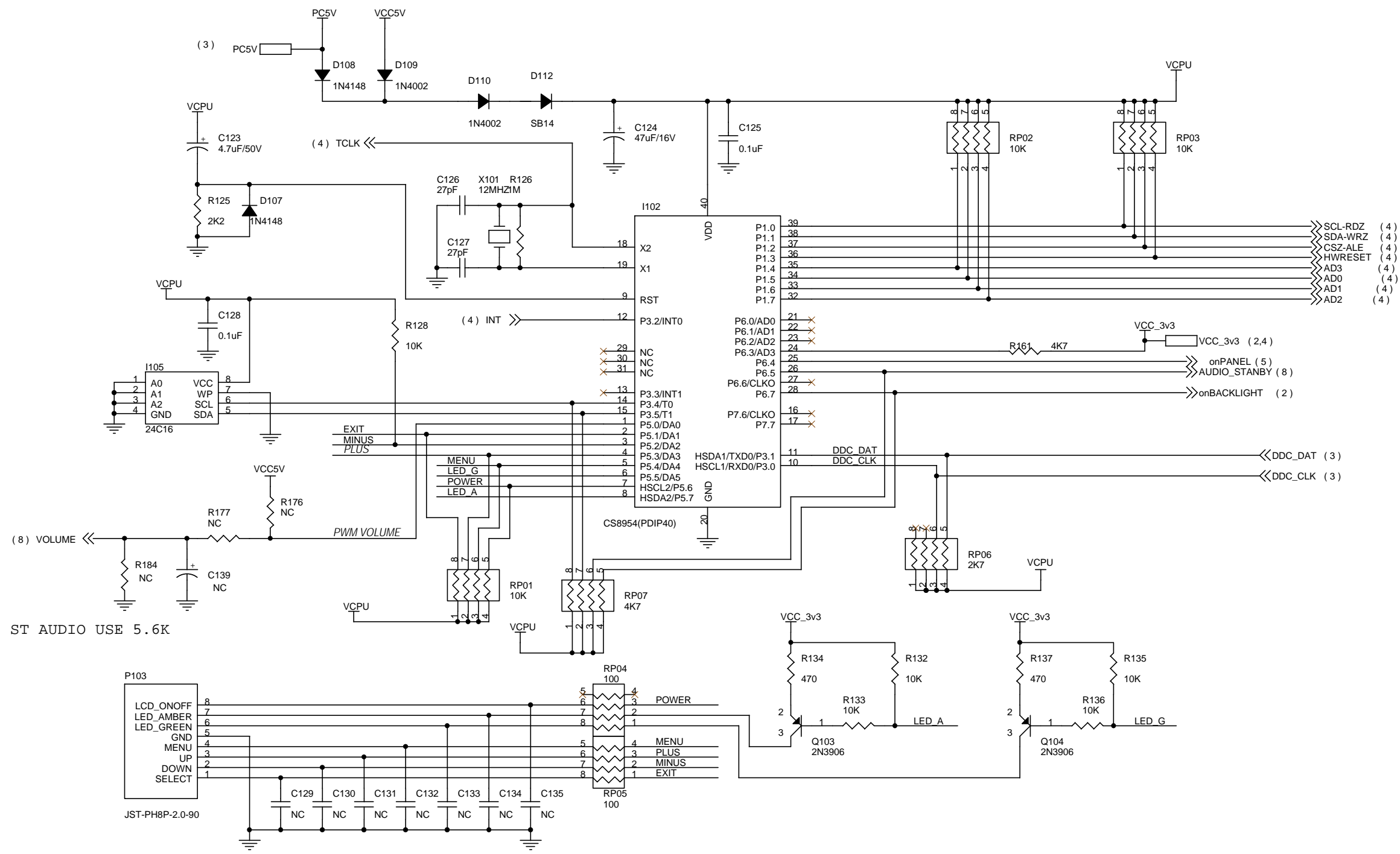

ViewSonic Corporation	
Model	MCU
Title	
Date	Rev:

10.6. KEY PAD

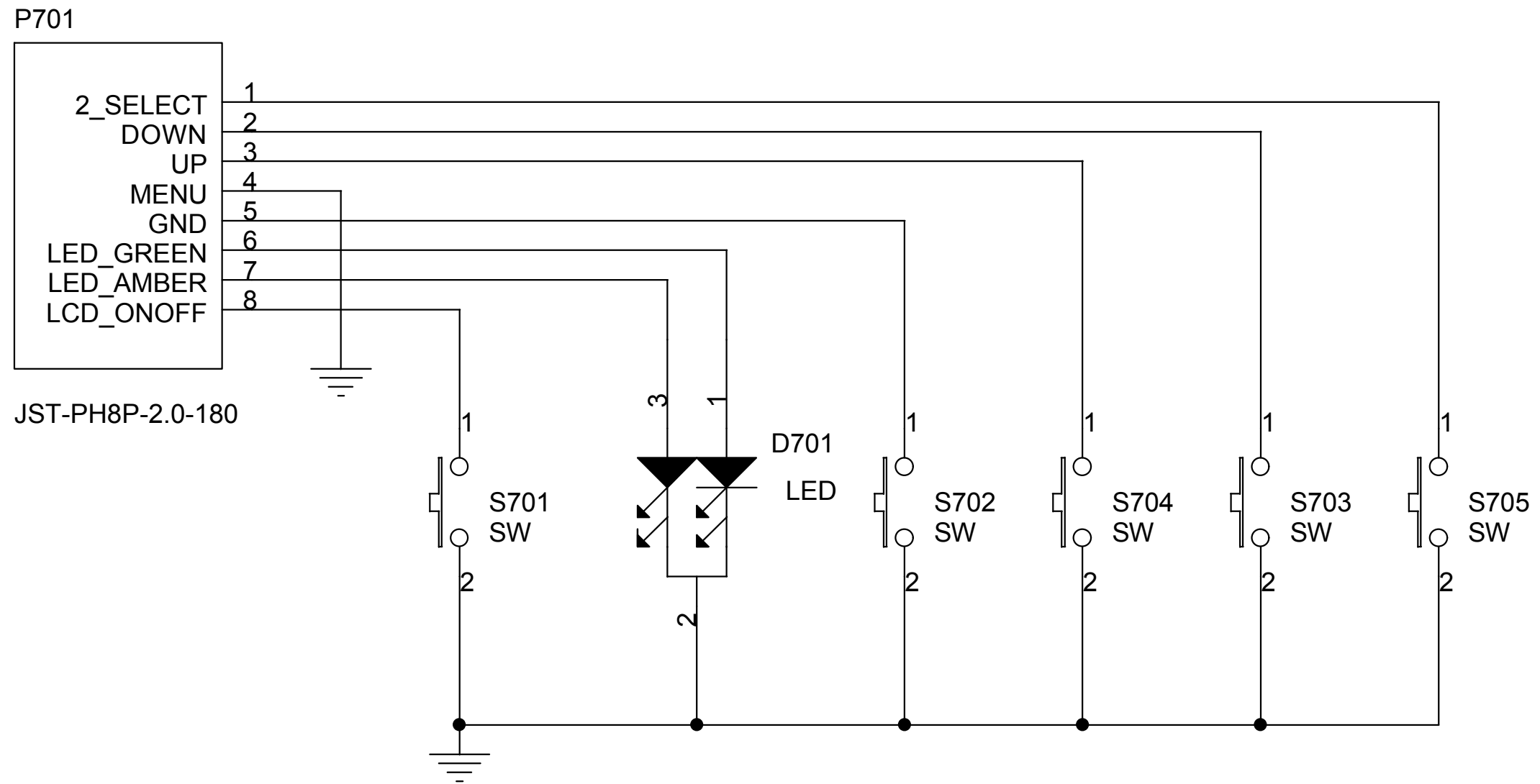

ViewSonic Corporation	
Model	KEY PAD
Title	
Date	Rev:

10.7. A/D POWER

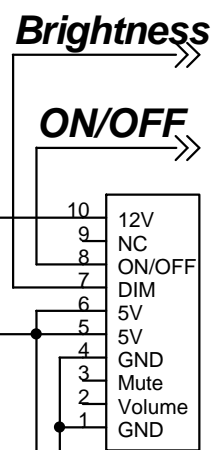
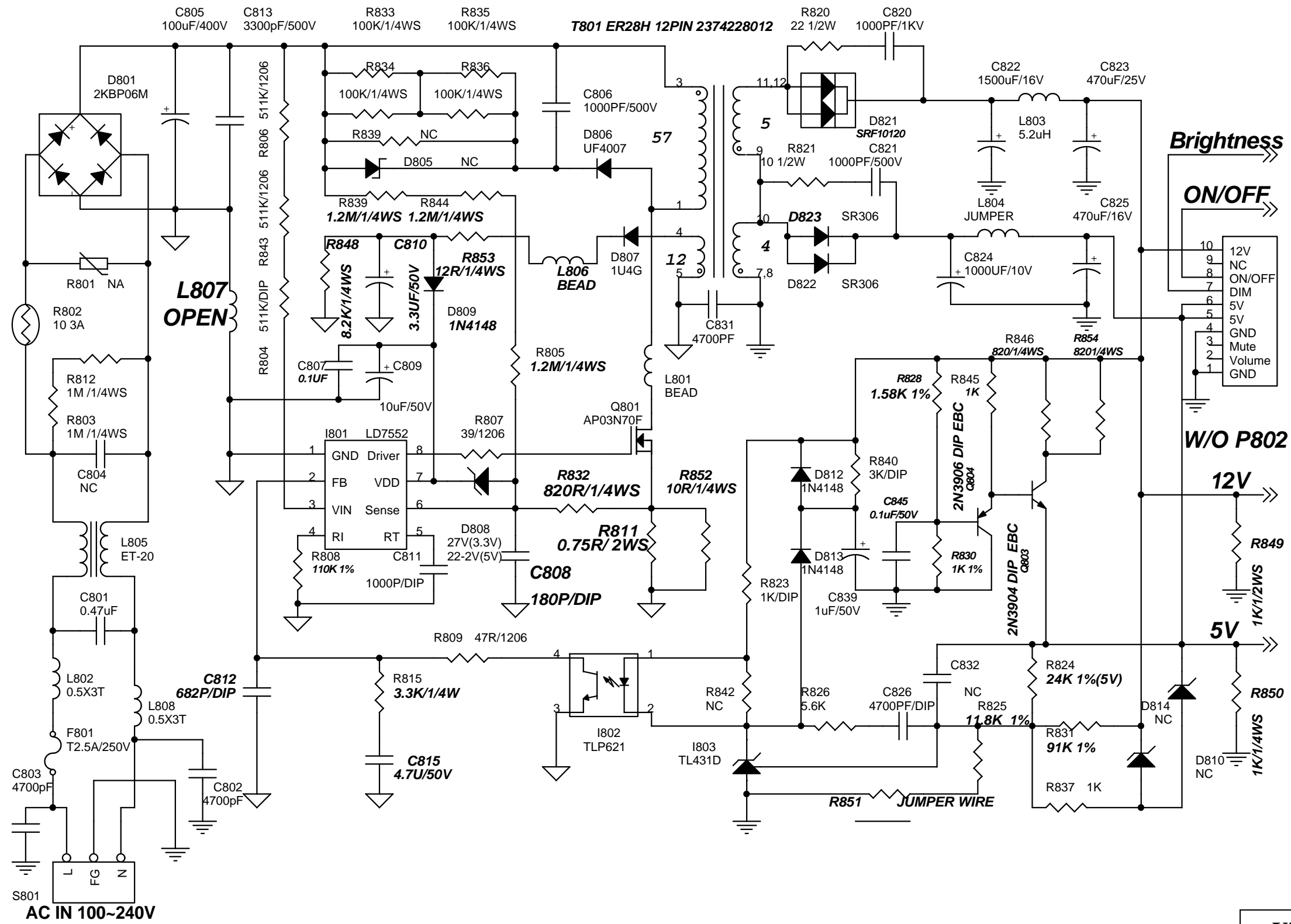

ViewSonic Corporation	
Model	POWER
Title	
Date	Rev:

10.8. INVERTER

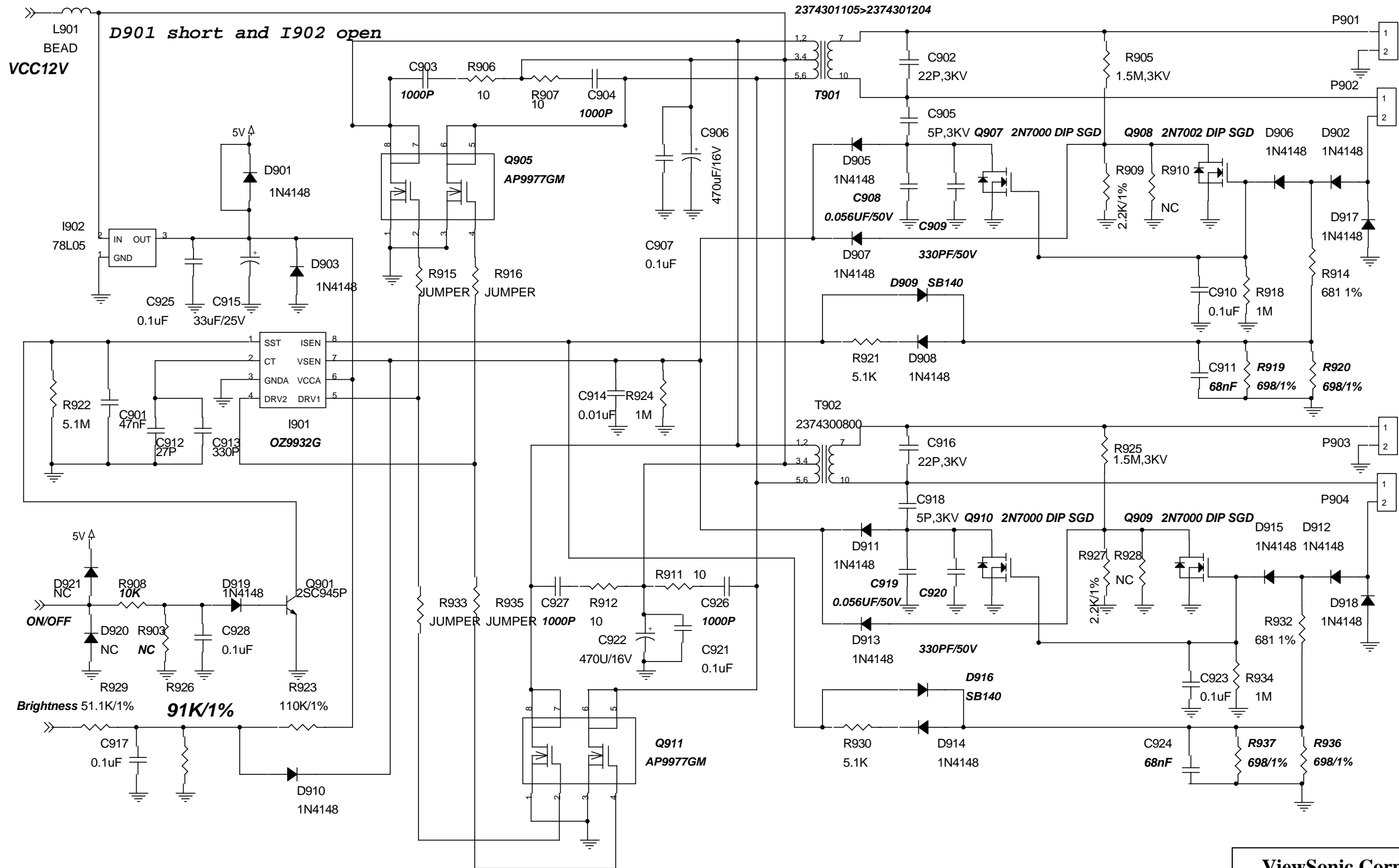

ViewSonic Corporation	
Model	
Title	
Date	Rev:

11. PCB Layout Diagrams

11.1. MAIN PCB TOP VIEW

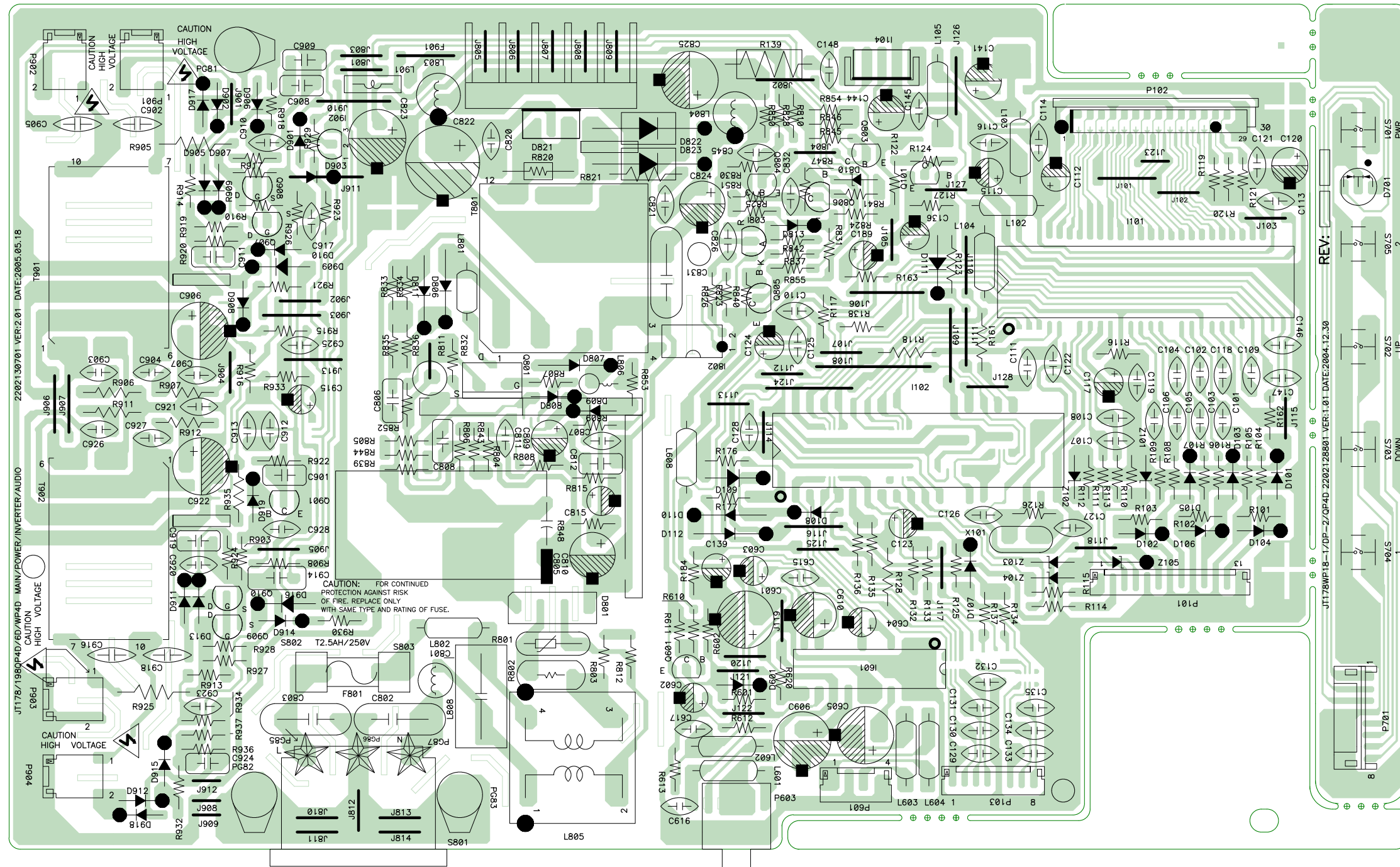

11.2. MAIN PCB BOTTOM VIEW

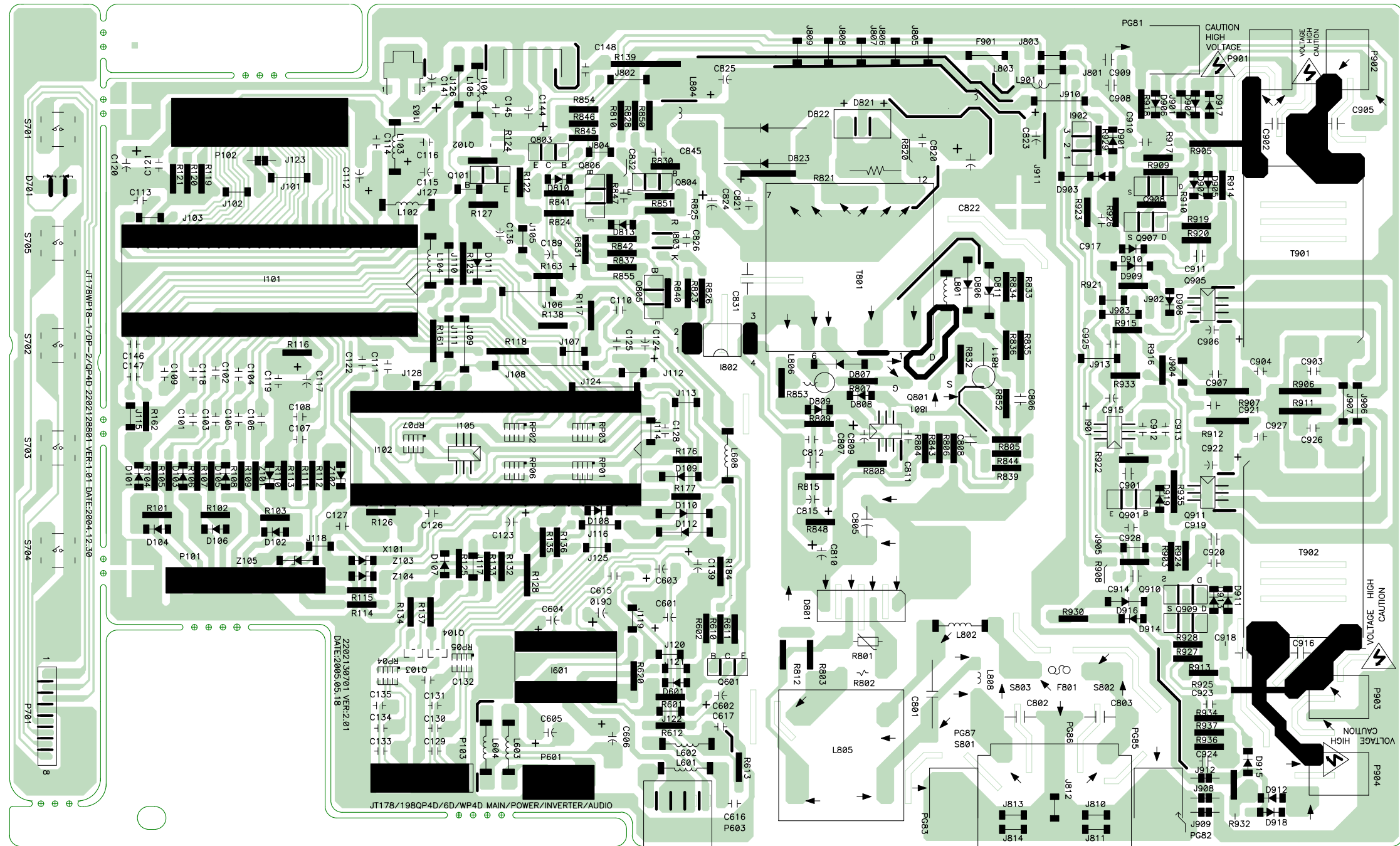

11.3. KEYPAD PCB TOP VIEW

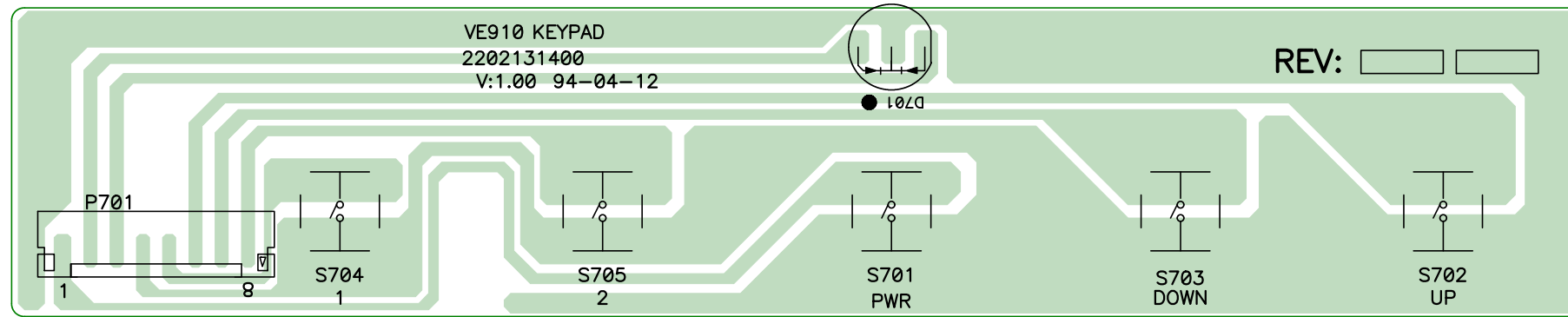

11.4. KEYPAD PCB BOTTOM VIEW

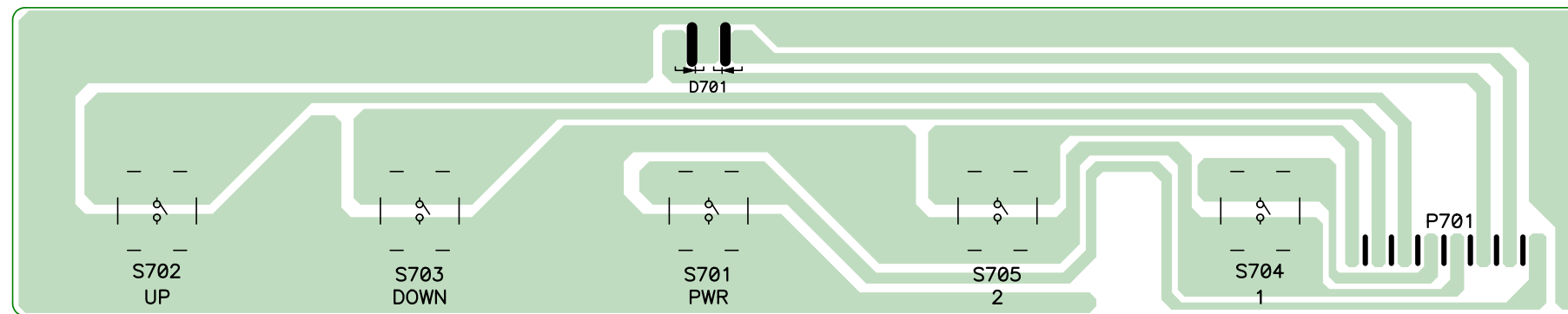

Reader's Response

Dear Readers:

Thank you in advance for your feedback on our Service Manual, which allows continuous improvement of our products. We would appreciate your completion of the Assessment Matrix below, for return to ViewSonic Corporation.

Assessment

A. What do you think about the content of this Service Manual?

<i>Unit</i>	<i>Excellent</i>	<i>Good</i>	<i>Fair</i>	<i>Bad</i>
1. Precautions and Safety Notices				
2. Specification				
3. Front Panel Function Control Description				
4. Circuit Description				
5. Adjustment Procedure				
6. Troubleshooting Flow Chart				
7. Recommended Spare Parts List				
8. Exploded Diagram and Exploded Parts List				
9. Block Diagram				
10. Schematic Diagrams				
11. PCB Layout Diagrams				

B. Are you satisfied with this Service Manual?

<i>Item</i>	<i>Excellent</i>	<i>Good</i>	<i>Fair</i>	<i>Bad</i>
1. Service Manual Content				
2. Service Manual Layout				
3. The form and listing				

C. Do you have any other opinions or suggestions regarding this service manual?

Reader's basic data:

Name:		Title:	
Company:			
Add.:			
Tel:		Fax:	
E-mail:			

After completing this form, please return it to ViewSonic Quality Assurance in the USA at facsimile 1-909-839-7943. You may also e-mail any suggestions to the Director, Quality Systems & Processes (marc.maupin@viewsonic.com)