

□ □ □	
□ □ □ □	3 □



Mendel Project Training Manual



Samsung Electronics Co.,Ltd
LCD Monitor R&D



Table of Contents



SAMSUNG

- Product Outline
- Circuit Guide
- Disassembly and Reassembly
- Diagnosis and Adjustments

1. Product Outline (Features)

Features

- Minimalism Design (Something New)
- New Concept Ball Hinge
- Color Variation - White, Black
- Boltless Model (Clean Cut & Soft Surface)
- PCB : 2 Layer, 118mm x 80mm (4layer)
- Micom inside Scaler, Flash Memory
- Memory & Scaler □□ □□ : SDR (Serial Data Rate) communication
- Connectivity : 17" inch Analog only / 19" inch Dual
- Power Consumption : 17" (34W), 19" (38W)
- DPMS : under 1 W (230Vac)
- □□ : Internal Power with Inverter (5V - 2A, 14V - 2.2A) - 100 ~ 240 Voltage

POWER NET, SEMCO

New function

- Auto Pivot □ - Simple Stand Only
- MagicZone Delete - Chip Limitation
- Dynamic Contrast

1. Product Outline (Models)

Model

WorldWide



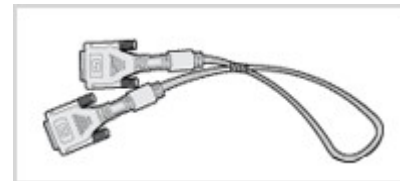

732N (LS17PBA) / Analog ONLY

932B (LS19PEB) / DUAL

Option : DVI Cable



1. Product Outline (Models)

	Sony (SDM-X95FS)	LG (L1940PQ)	Acer (A1951)	Dell (E193FP)	Samsung	
					932B	732N
Design						
Resolution	1280x1024	1280x1024	1280x1024	1280x1024	1280x1024	
Input	D-Sub, DVI-D	D-Sub, DVI-D,	D-Sub, DVI-D	D-Sub	D-Sub, DVI-D	D-Sub
R/T (w to b*)	16 ms	8ms	8ms	16 ms	5ms	
Viewing	170/170	170/170	150/135	140/140	160/160(CR*>10)	
Brightness	300cd/m ²	300 cd/m ²	300 cd/m ²	250cd/m ²	300cd/m ²	
Contrast Ratio	700:1	700:1	700:1	500:1	1000:1 (Dynamic Contrast On 2000:1 □)	
Speaker	1W *2	-	1.5W *2	-	-	
Feature	HAS(110mm) Tilt(-5~20), Swivel(350) Eco mode Side button	Ag+ Coating F-engine	1 Hinge Built-in speaker		Magic Color Magic Bright2 Magic Tune Deleted MagicZone	

*w to b : white pattern □ black pattern □□□ panel □□□

*CR : Contrast Ratio

1. Product Outline (Models)



Key Specification		
Model	732N	932B
□□ □□	17"	19"
□□□	1280x1024@75Hz	1280x1024@75Hz
Colors	16.7M	16.7M
□ □	300cd/m ²	300cd/m ²
□ □ □	1000:1 (Dynamic Contrast On 2000:1 □□)	1000:1 (Dynamic Contrast On 2000:1 □□)
□□ □□□	VGA ~ SXGA	VGA ~ SXGA
□□ □□□	30~81kHz	30~81kHz
Sync Type	Sep./Comp./SOG	Sep./Comp./SOG
□□ □□□	56~75Hz	56~75Hz
Viewing Angle	160°/160° (CR=10)	160°/160° (CR>10)
□□ □□	5ms (w to b)	5ms (w to b)
Signal Input	Analog R,G,B	Analog R,G,B / DVI
□□ □□	34 Watt (Max)	38 Watt (Max)



1. Product Outline (Product Spec)



Key Specification		
Model	732N	932B
□□ □□	17"	19"
□□□	1280x1024@75Hz	1280x1024@75Hz
Colors	16.7M	16.7M
□ □	300cd/m ²	300cd/m ²
□ □ □	1000:1 (Dynamic Contrast On 2000:1 □□)	1000:1 (Dynamic Contrast On 2000:1 □□)
□□ □□□	VGA ~ SXGA	VGA ~ SXGA
□□ □□□	30~81kHz	30~81kHz
Sync Type	Sep./Comp./SOG	Sep./Comp./SOG
□□ □□□	56~75Hz	56~75Hz
Viewing Angle	160°/160° (CR=10)	160°/160° (CR>10)
□□ □□	5ms (w to b)	5ms (w to b)
Signal Input	Analog R,G,B	Analog R,G,B / DVI
□□ □□	34 Watt (Max)	38 Watt (Max)

1. Product Outline (Spec)



Key Specifications	
Model	732N/932B
Swivel	N.A
Stand	Simple
Pivot	N.A
□□ □□	N.A
Power Supply	□□□ IP Board
Tilt(forward / backward)	0°(Forward) 0° ~ 23°(Backward)
Safety Mode	UXGA □□ Display □□
Magic Bright II /Magic Color	Support(□□) (MagicZone □□□□)
 	
Emissions Standard	TCO99
Magic Tune	Version 3.6
	

1. Product Outline (Function Description)

Key Specification		
Function	Detail function	Function Description
Magic color	Off	Magic Color Off function
	Demo	Only for the display on the market. Magic Color On is operated on the left, and Magic Color Off on the right
	Full	Expand the 3 Color Tone, R/G/B, and display vivid natural color
	Intelligent	The function to expand RGB color except the skin tone.
Magic Bright	Custom	Factory defaults
	Text	The brightness setting for the documentation work. (100 ~ 160 cd/m2)
	Internet	The brightness setting for the Internet use. (140 ~ 200 cd/m2)
	Game	The brightness setting for the Internet Game. (225cd/m2 and grater)
	Sports	The brightness and color temperature setting for sports programs. (180 cd/m2 and greater , 8000K)
	Movie	The brightness and color temperature setting for movies. (200 cd/m2 and greater, 6500K)
Color Tone	Cool	The highlighted blue tone by changing the RGB color(9300K)
	Normal	Natural tone without any change in RGB color
	Warm	The highlighted red tone by changing RGB color (6500K)
	Custom	User customized tone with the manual RGB color control

1. Product Outline (M agic Color)

Magic color Demo Mode



Demo
M ode

Magic color Full Mode

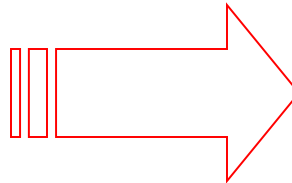
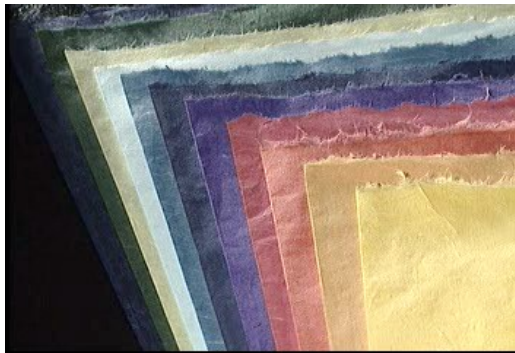

Expand all
three of R /G /B

1. Product Outline (M agic Color)

Magic color
Intelligent Mode

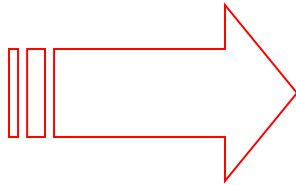

Except
Skin Tone

1. Product Outline (Gamma)

Gamma

Key Specification		
Function	Detail function	Function Description
Gamma	Mode 1	Set with the basic Gamma which is supported from the panel. (Gamma 2.1)
	Mode 2	Generally bright mode which is controlled in Scaler (Gamma 2.3)
	Mode 3	Generally dark mode which is controlled in Scaler (Gamma 2.5)
Sharpness	Sharpness	When texts are overlapped or get broader because of the excessive peaking on the PC input signal, use Sharpness function to adjust texts to be smooth and clear.

1. Product Outline (OSD Function)



1. MENU
2. 1)MagicBright™ / Down
2)Brightness / Up
3. 19" : Enter / Source 17" : Enter
4. Auto

Power Button



1. Product Outline (OSD function)

MENU button Detailed description of OSD

1  Open the OSD menu. Also use to exit the OSD menu or return to the previous menu.

2 **MagicBright™ Button**  Press this button to adjust MagicBright™. MagicBright™ is the monitor with more than two times brighter and clearer picture quality than existing monitors to provide the display according to the different kinds of user environment such as word processing, internet, and video, etc. You can easily select one of six settings by simply pressing MagicBright control button on the monitor front.

1) **Custom** Although the brightness and contrast are carefully set by engineers, the pre-configured values may not be comfortable to your eyes. In this case, adjust the brightness and contrast on the OSD menu.

2) **Text** Select this mode to set the monitor with the proper brightness for works involving heavy texts.

3) **Internet** Select this mode to set the monitor with the proper brightness in Internet (texts and graphics) environment





4) **Game** Select this mode to set the monitor with the proper brightness in game (full of graphics) environment.

5) **Sport** Select this mode to set the monitor with the proper brightness in a sport environment







6) **Movie** Select this mode to enjoy movies, DVD, and TV with the brightness and resolution close to TV.

1. Product Outline (OSD function)

OSD Function

- 3 Brightness Adjust buttons [] Adjust the brightness.
- 2, 3  Adjust items in the menu and set value.
- 4 Enter Button [] / AUTO button Press to select the function.
- 5 Power button [] / Power indicator  Press this button for auto adjustment.
- 6 Press to turn the monitor on and off./
The light glows blue during normal operation.

1. Product Outline (OSD Tree)

 (Picture)	 (Color)	 (Image)	 (OSD)	 (Set Up)	 (Information)	 (Magic Bright)
<ul style="list-style-type: none"> - Contrast - Brightness 	<ul style="list-style-type: none"> - Color Tone <ul style="list-style-type: none"> .Cool .Normal .Warm .Custom - Color Control <ul style="list-style-type: none"> .Red .Green .Blue - Gamma <ul style="list-style-type: none"> .Mode1 .Mode2 .Mode3 - MagicColor <ul style="list-style-type: none"> .off .Demo .Full .Intelligent 	<ul style="list-style-type: none"> - Fine - Coarse - Sharpness - H Position - V Position 	<ul style="list-style-type: none"> - Language - Position <ul style="list-style-type: none"> .H Position .V Position - Transparency - Display Time 	<ul style="list-style-type: none"> - Auto Source - Color Reset - Image Reset 	<ul style="list-style-type: none"> - Resolution - Frequency - Input Source 	<ul style="list-style-type: none"> - Custom - Text - Internet - Game - Sport - Movie

1. Product Outline (OSD Hidden Key)

No	Function	Operating method
1	User delete (Restore Factory Default Settings)	Select Brightness when the menu is displayed and press and hold the Enter key for 5 seconds.
2	Service Menu	Adjust the Brightness and Contrast on the menu to '0', and press and hold the Enter key for 5 seconds while the menu is displayed.
3	Color calibration	Select OSD/Language English when the menu is displayed, then press the Enter key for 5seconds. (Screen is 16Gray.)
4	Menu Lock	Press the Menu key for 5 seconds.

1. Product Outline (Display Modes)

Display Mode	Horizontal Frequency (kHz)	Vertical Frequency (Hz)	Pixel Clock (MHz)	Sync Polarity (H/V)
IBM, 640 x 480	31.469	59.940	26.175	+/-
IBM, 720 x 400	31.469	70.087	28.322	-/+
VESA 640 x 480	37.5	75	31.5	-/-
VESA 800 x 600	37.879	60.317	40.0	+/+
VESA 800 x 600	46.875	75.0	49.5	+/+
VESA 1024 x 768	48.363	60.004	65.0	-/-
VESA 1024 x 768	60.023	75.029	78.750	+/+
VESA 1280 x 1024	63.981	60.020	108.00	+/+
VESA 1280 x 1024	79.976	75.025	135.0	+/+
SUN 1280 x 1024	81.129	76.106	135.00	-/-

2. Circuit Guide (Product Structure)

1. Panel Part

- Refer to the product specifications

2. Mainboard Part

- Receive the PC analog and DVI signals from the external devices and output the video signal to the panel by using the Scaler, then output the same signal as the external input.

3. IP BOARD

- Inverter + SMPS BOARD

4. Function key

- Transfer the input signal using the Function key to the mainboard and indicate with the LED

2. Circuit Guide (Scaler)

- Scaler (gm5726)

Embedded MCU Core Type

- Detail Spec

- On-Chip Microcontroller
 - X86 MCU
 - External Ram
- Advanced Color Control (ACM-3D)
 - ACM(Active Color Management)
: Adjust Color Saturation Level for Skin Tone Setting
- On-Chip OSD Controller □
- LVDS/RSDS Transmitters
- Output Resolution : SXGA
- 128-QFP Package

2. Circuit Guide (Panel Part)

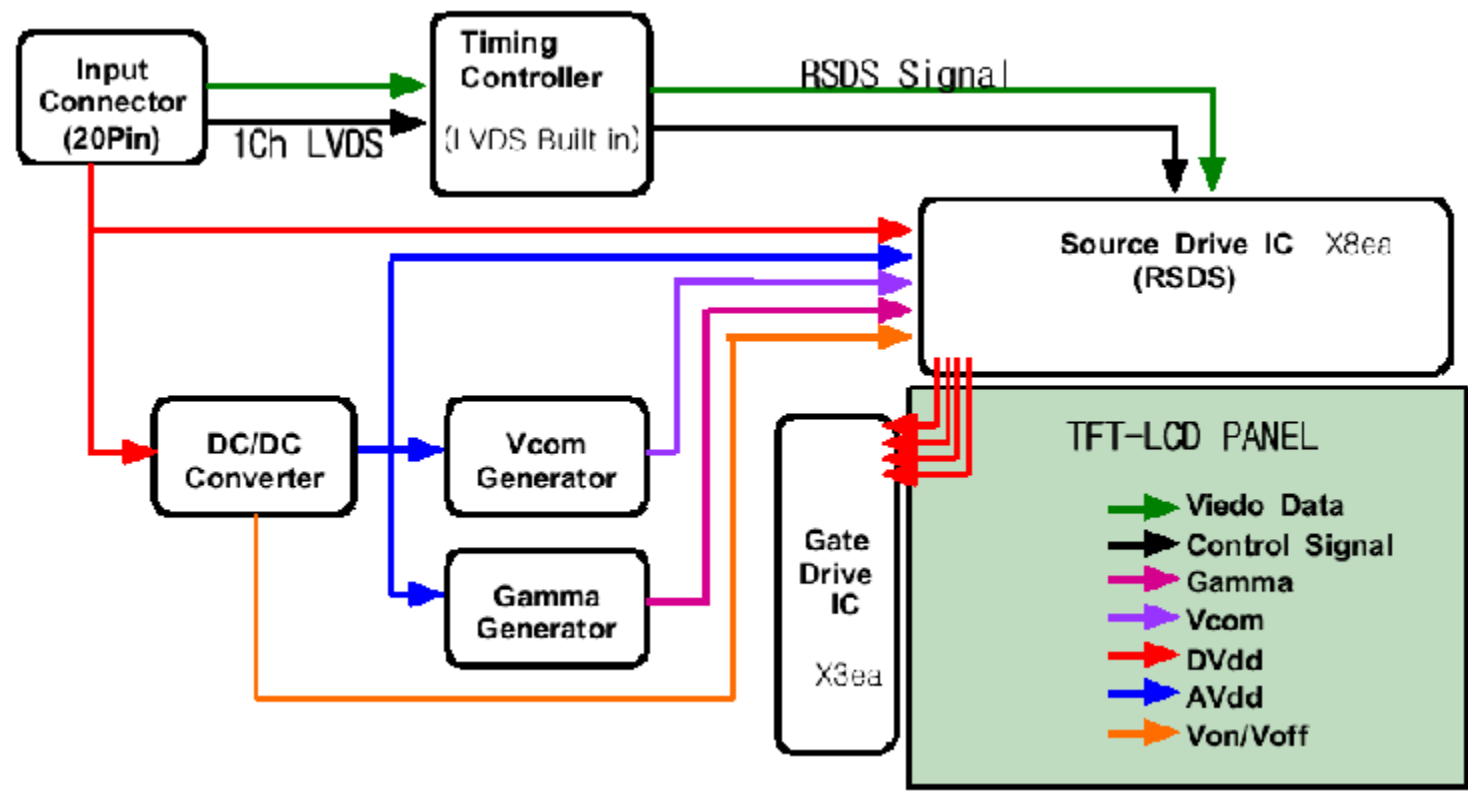

2. Circuit Guide (Panel Part)

* PROTECTION*

➤ LAMP(Inverter) PROTECION

=> The Protection activates when the Lamp Connector is disconnected or there is no feedback because of a crack on the lamp

=> When the output voltage of Inverter Trans is high, the Lamp Protection activates as Over Voltage Protection.

➤ Power Protection

=> All of the Protection(OVP/OCP) for the panel runs in Auto Recovery Mode. As a result, the power action is automatically performed again although the Protection activates all at once. But exceptionally for the Thermal Protection, it is properly performed only when the power is turned off and turned on again after the electric discharge. This activates by the function designed inside of the Power IC.

2. Circuit Guide (Main Block Diagram)

* 19" : Dual Model

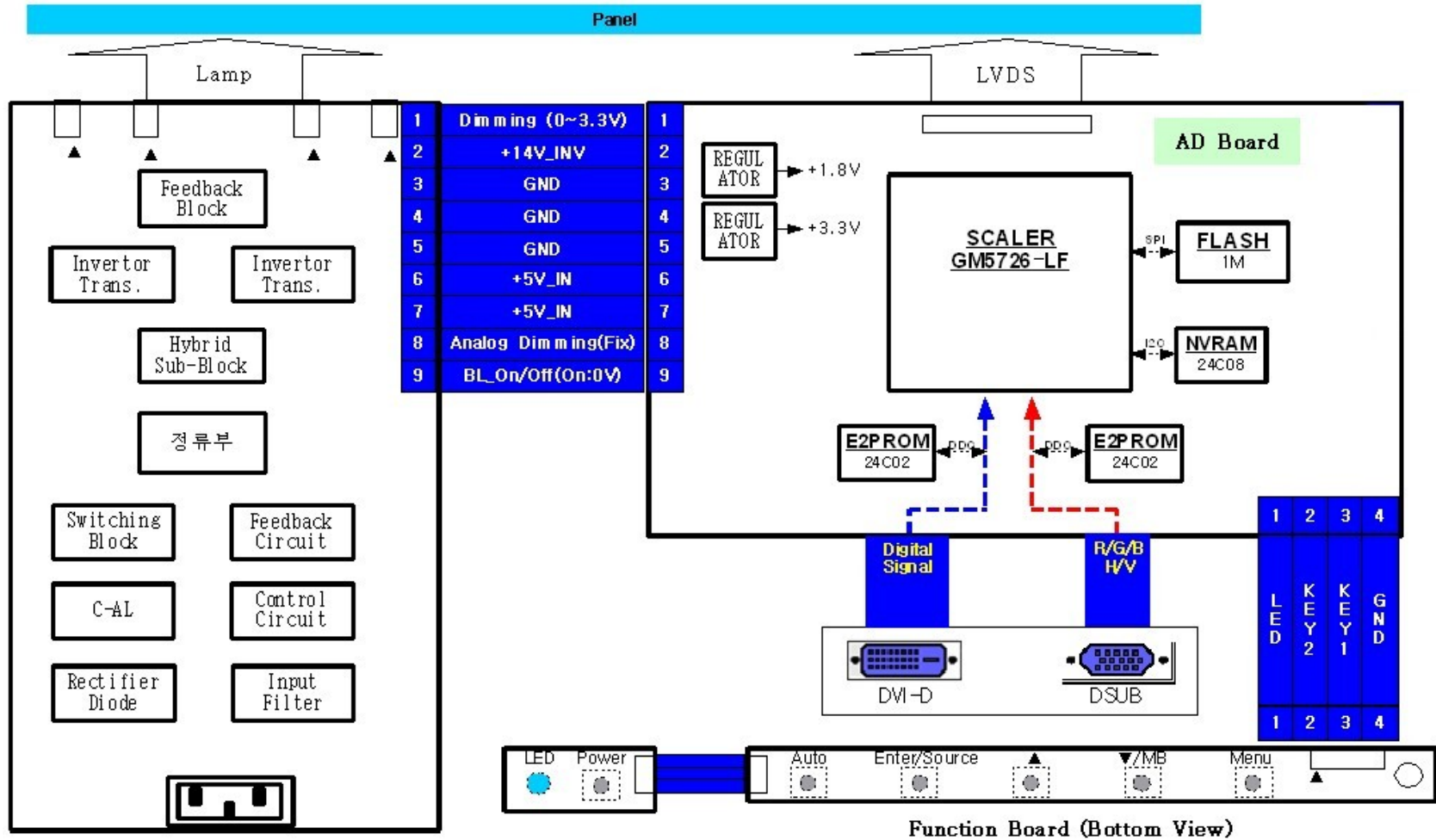

2. Circuit Guide (Main Block Diagram)

* 17" : Analog Only Model

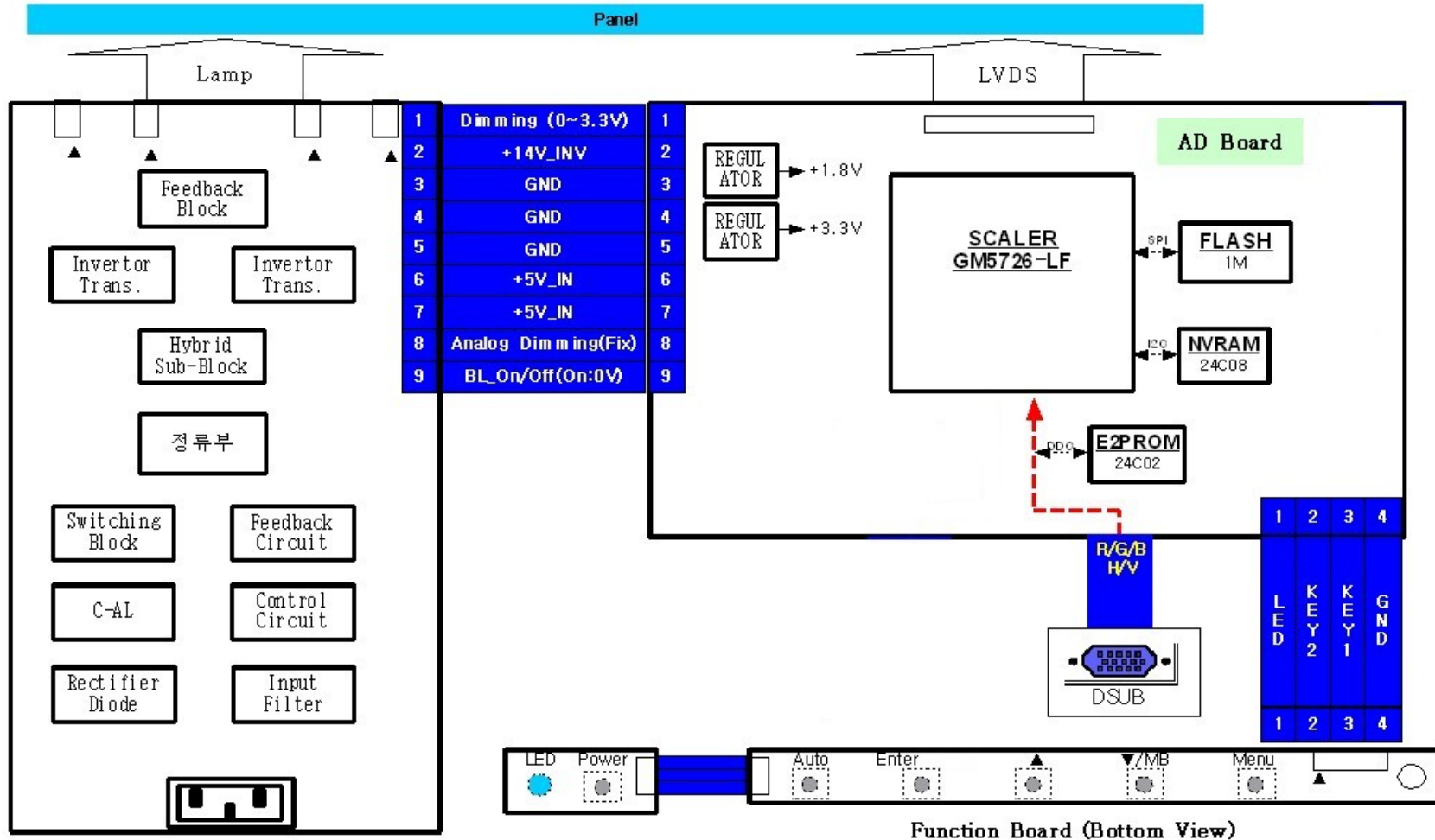

2. Circuit Guide (Power Flowchart)

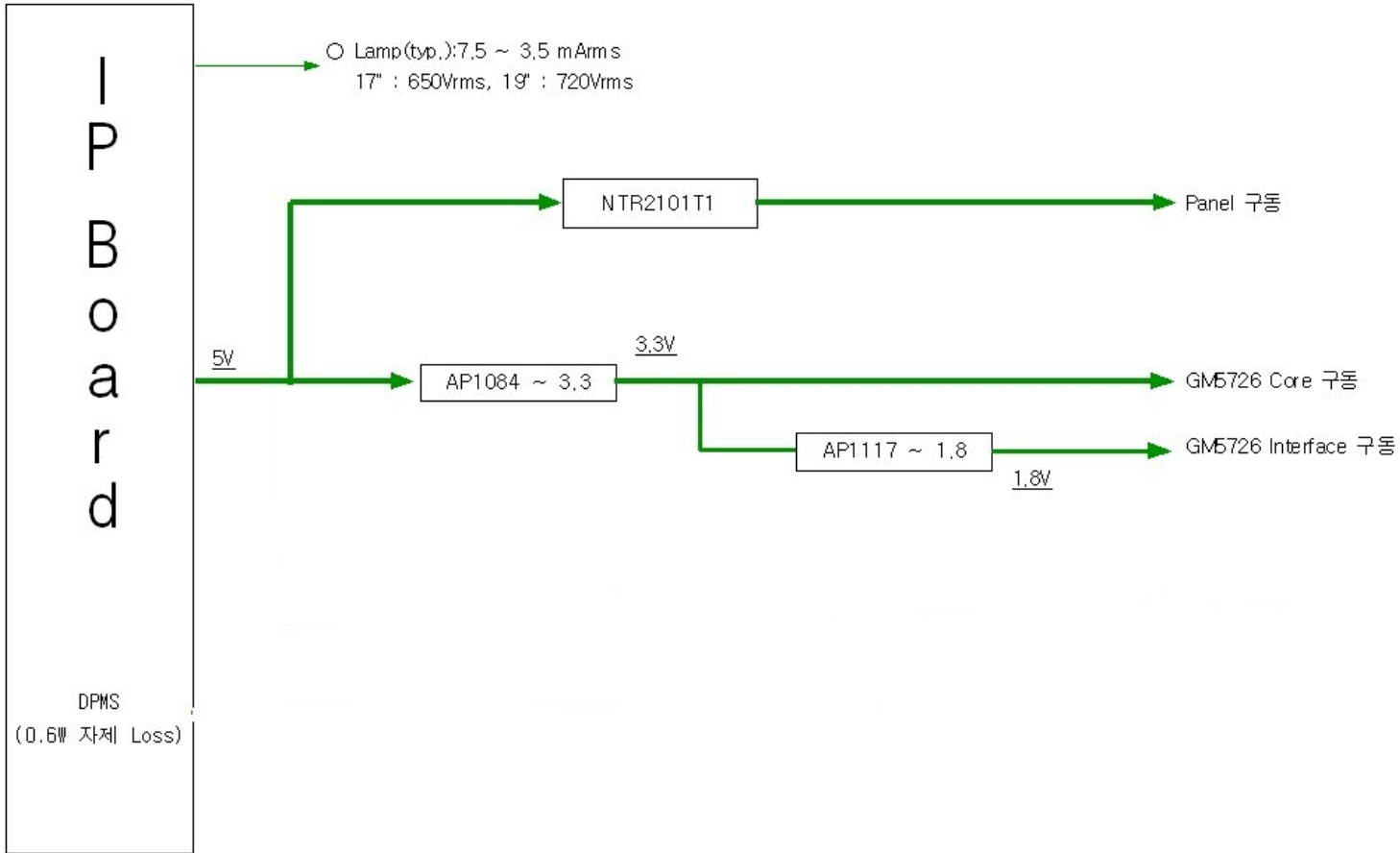

2. Circuit Guide (Main Block Diagram)

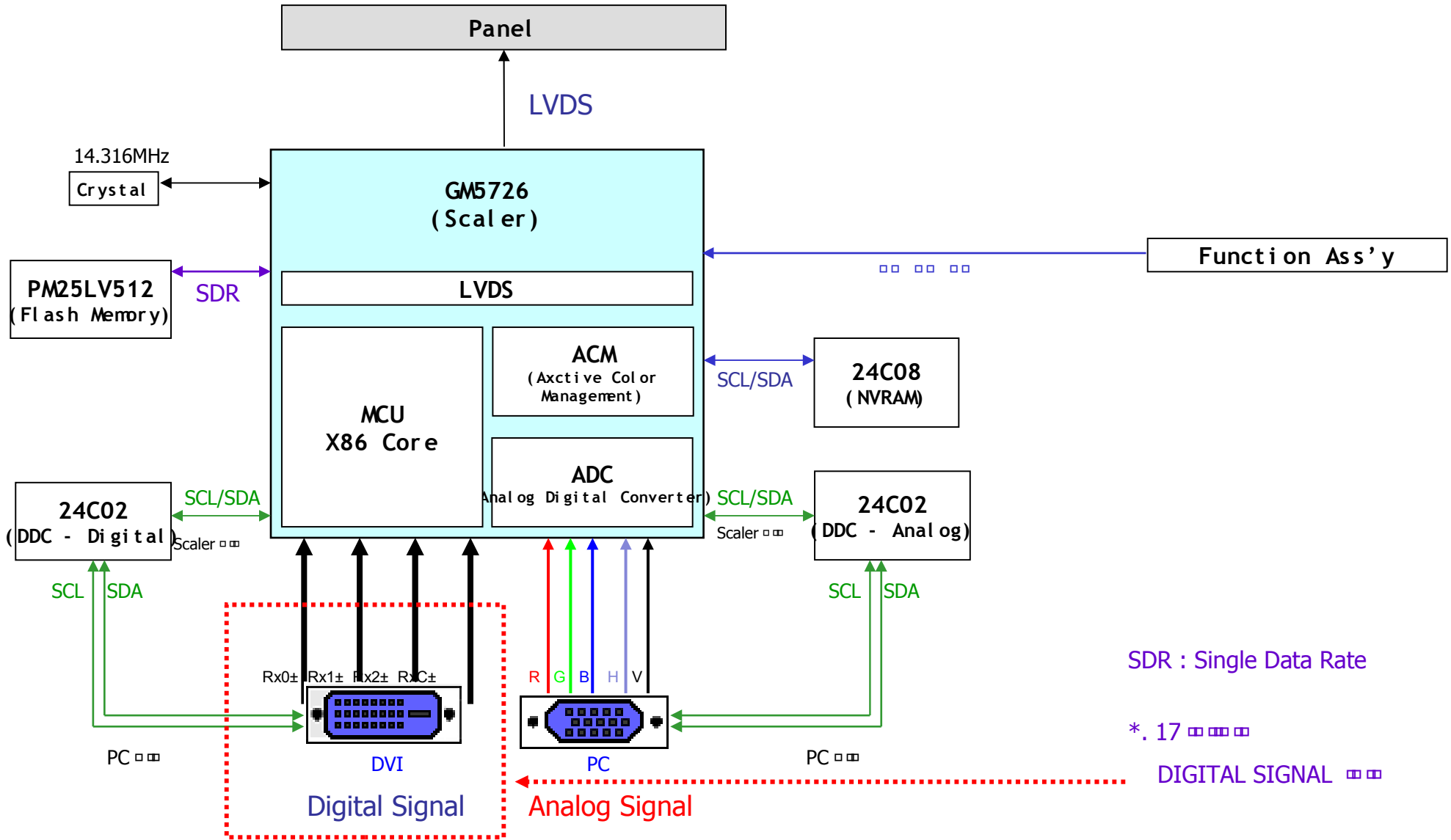

SDR : Single Data Rate

*. 17 □□□□

DIGITAL SIGNAL □□

2. Circuit Guide (Circuit Schematic Diagram)

* 19" : Dual Model

Signal Cable
DVI Input

Signal Cable
VGA Input

IP Board

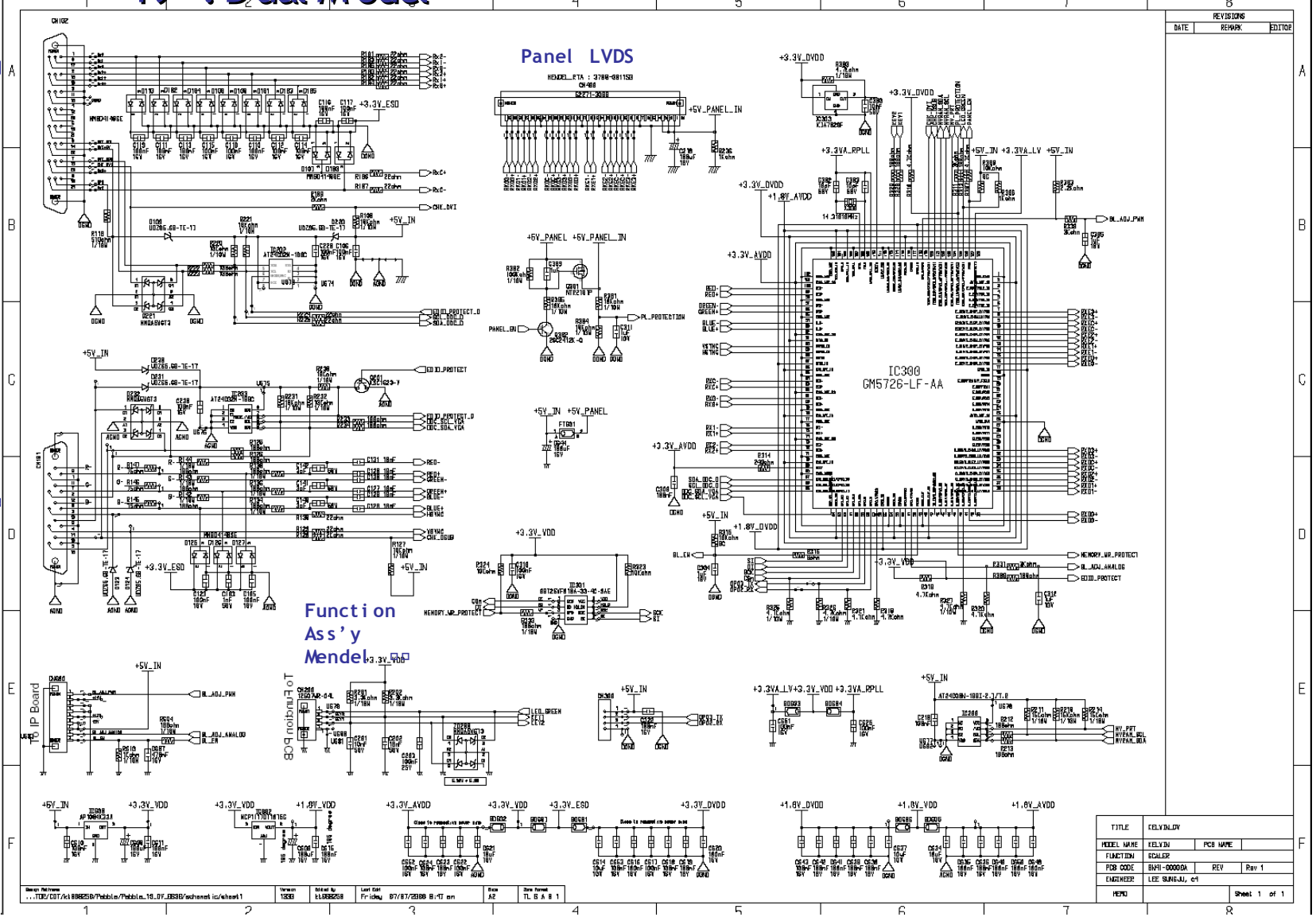

DATE	REVISIONS	EDITOR

TITLE	CELYN.DVI
MODEL NAME	CELYN
FUNCTION	SCALER
FOR CODE	SHI-00000A
REV	Rev 1
ENGINEER	LEE SANG-JU, ct

2. Circuit Guide (Main PBA) :19 inch

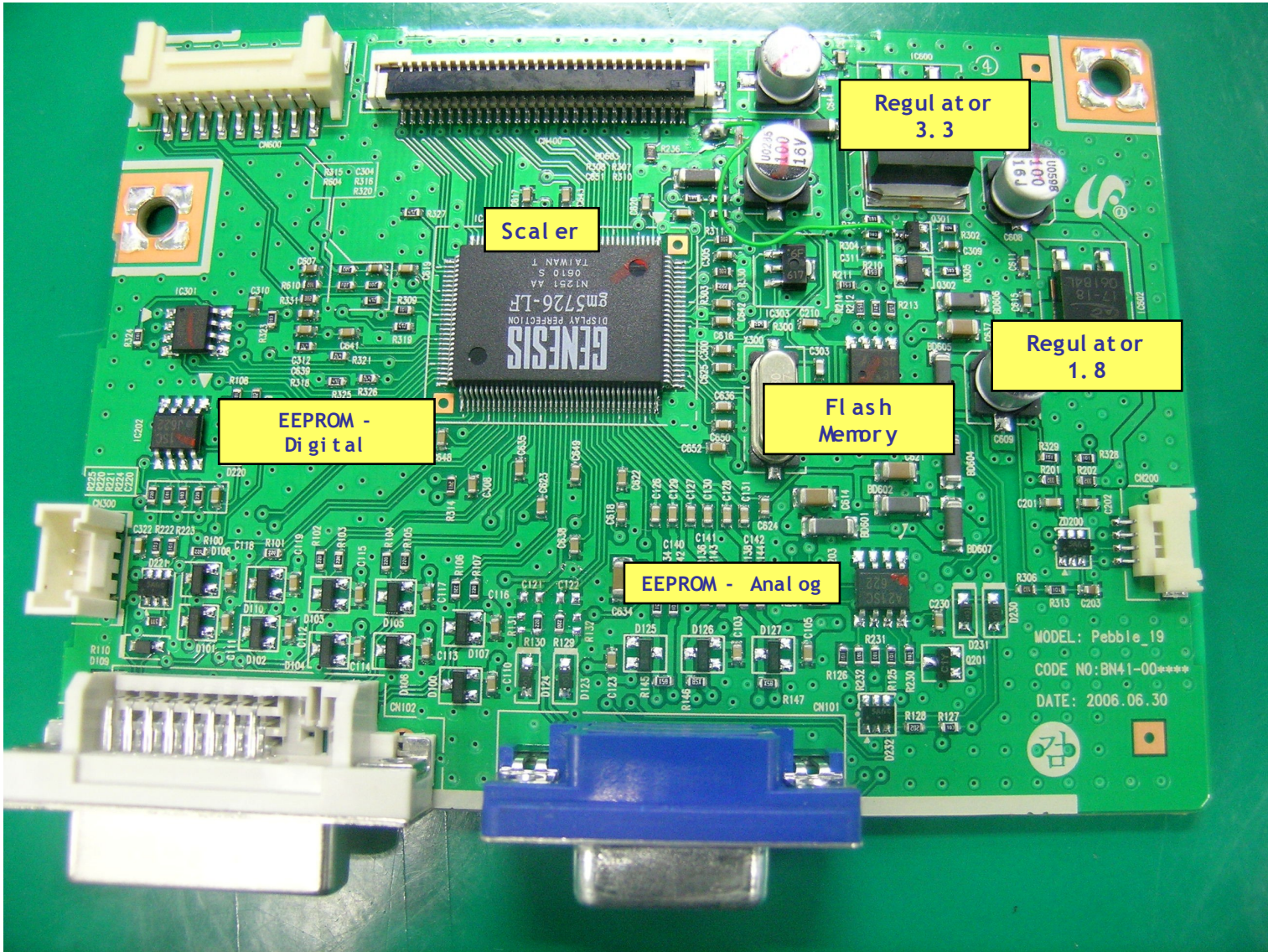

2. Circuit Guide (Main PBA) 17 inch

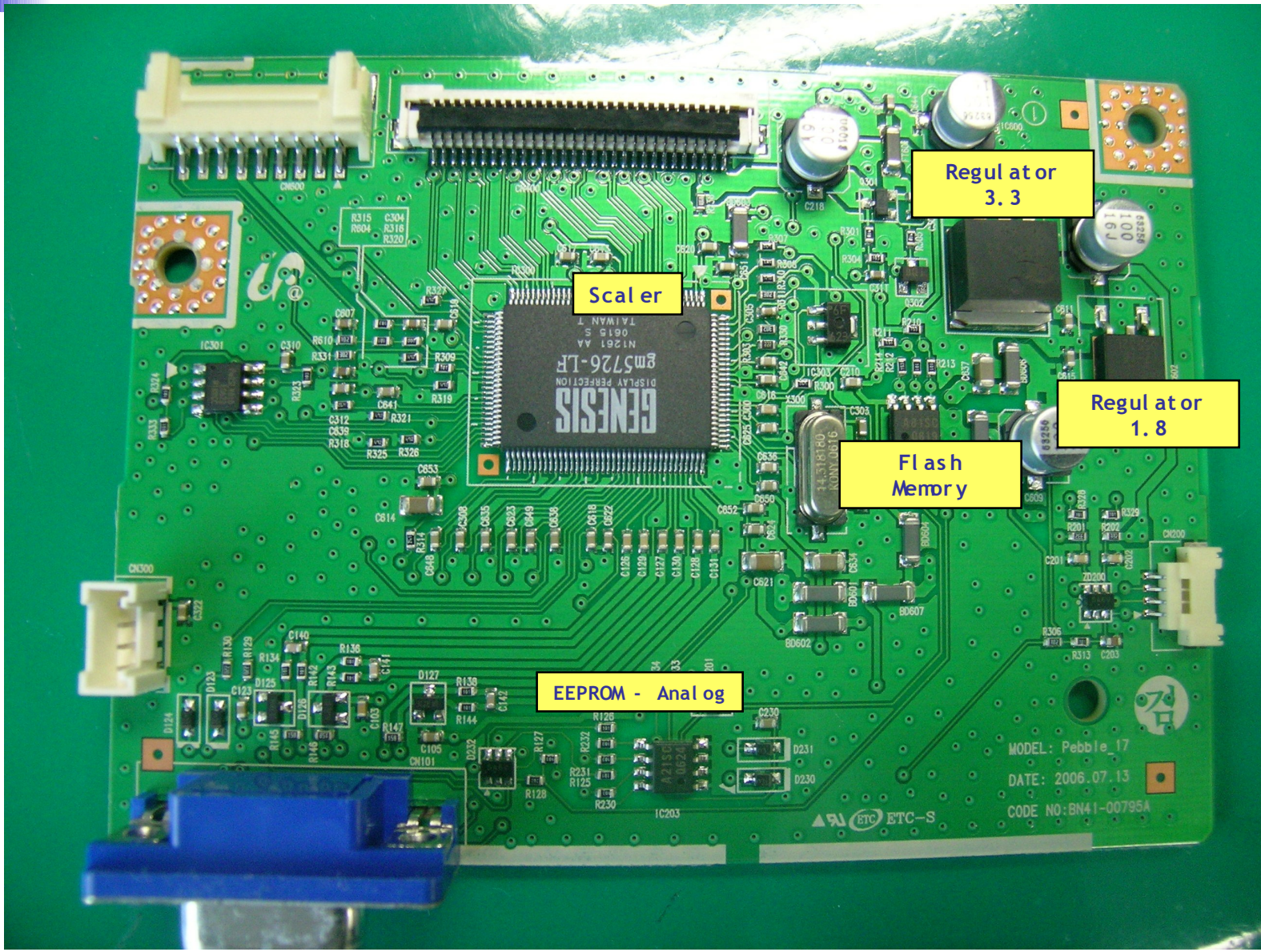

Scal er

Regul at or 3.3

Regul at or 1.8

Flash Memory

EEPROM - Analog

MODEL: Pebble 17
DATE: 2006.07.13
CODE NO: BN41-00795A

2. Circuit Guide (Main PBA)

No	Block	Description	Note
1	Scaler IC300	Not only ADC, LVDS, and Scaling part, but also MCU is embedded and integrated in one chip.	Gm5726-LF (For SXGA)
2	Flash Memory IC301	Stores the MCU program embedded in the Scaler and supports the firmware re-writing in the Flash type.	PM25LV512
3	IC200	Stores the OSD values and all kinds of the Time involved values.	24C08
4	IC202,203	This memory inputs Analog and Digital DDC.	24C02
5	Regulator	This IC receives the direct current voltage and is applied to the smaller direct current stabilized circuit.	AP1084K33A AP1117D-18A
6	IC500	Use as the switch connecting 14V to 5V when input Anion selectively.	FDS9933A

2. Circuit Guide (IP Board)

SMPS Part

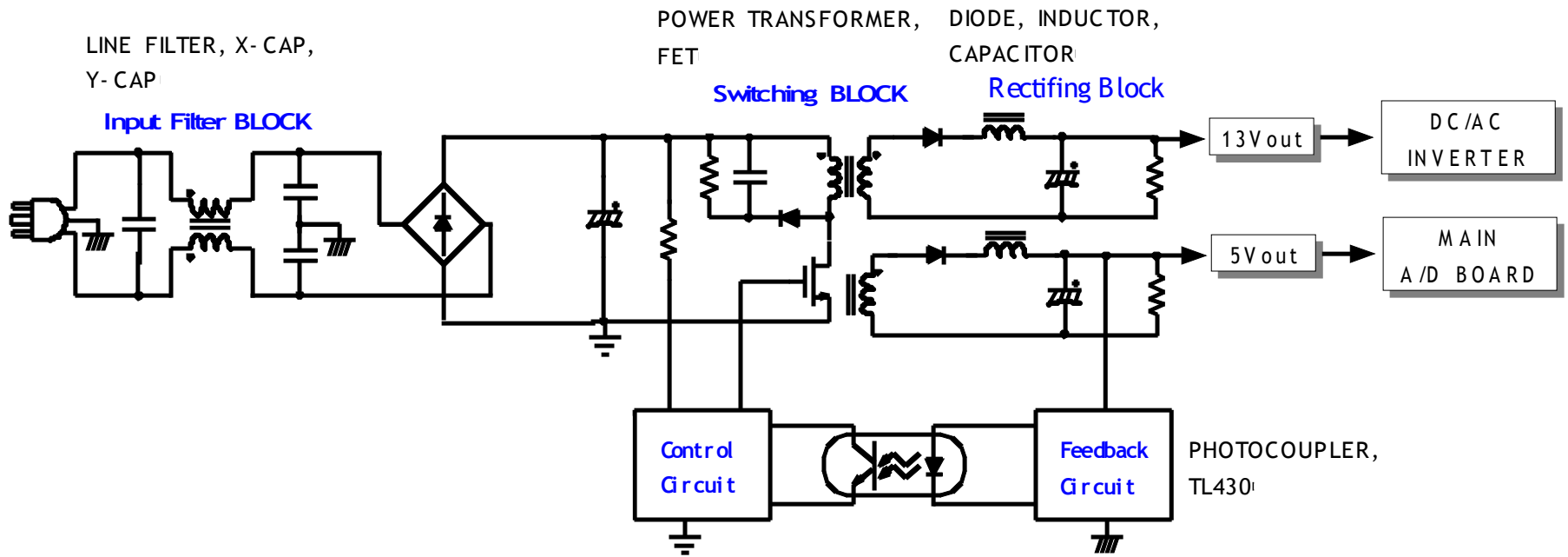

2. Circuit Guide (IP Board)

Inverter Part

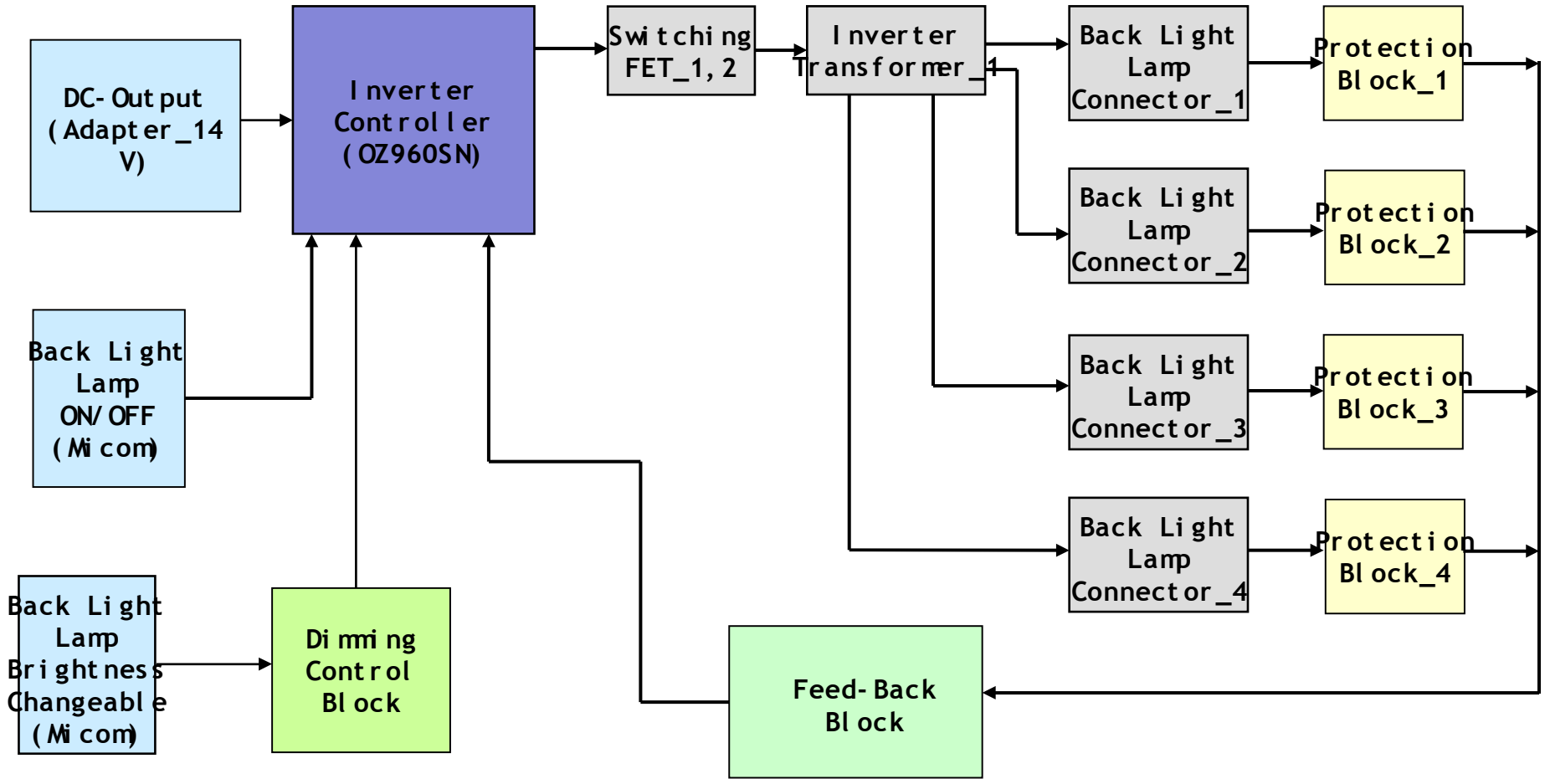

2. Circuit Guide (IP Board Circuit Schematic Diagram)

Inverter Part

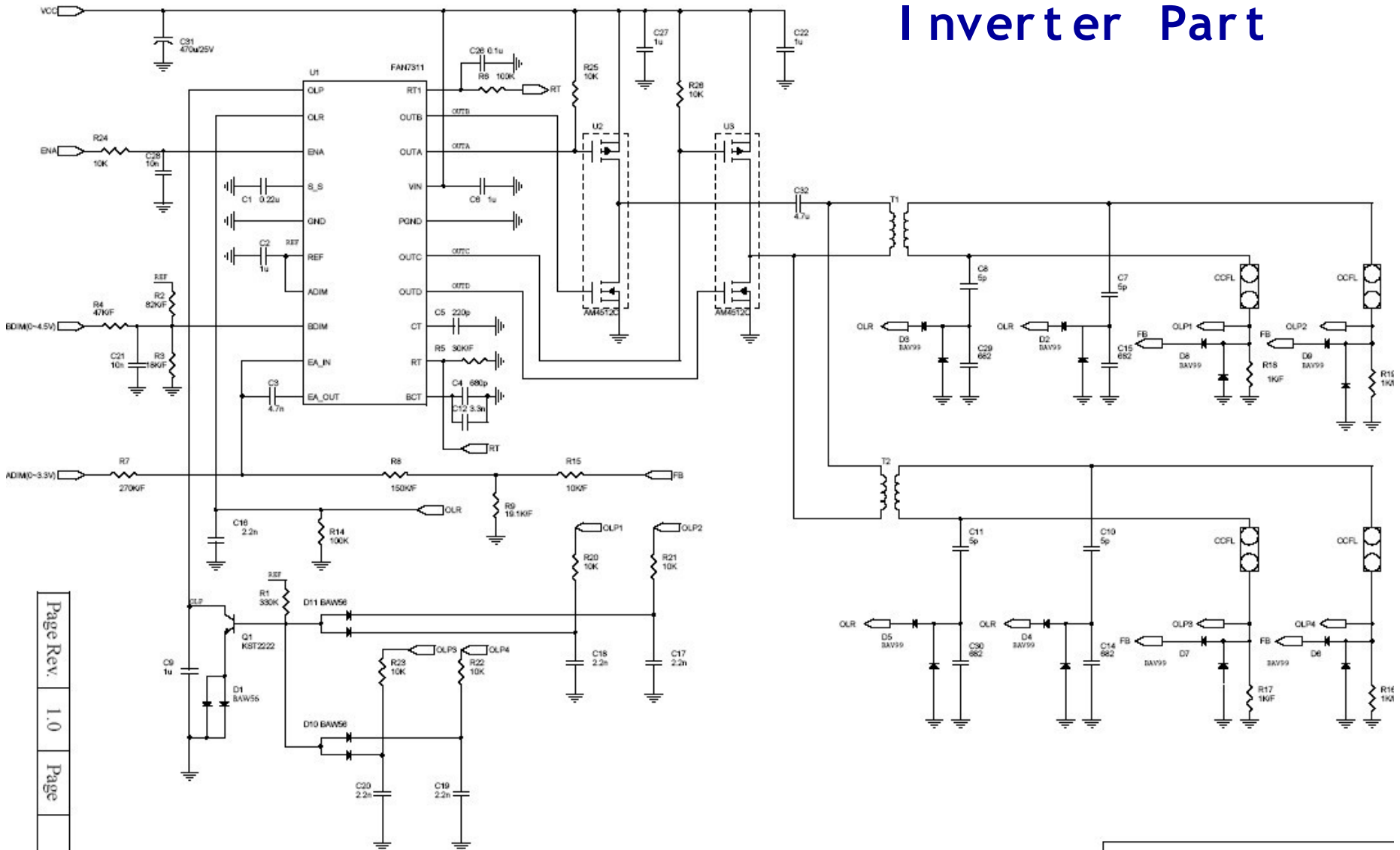

2. Circuit Guide (IP Board - Dimming)

The **Current Control** method controls the current intensity which flows to the lamp. In the **PWM** method, the lamp flickers in a certain frequency. Those two methods are mixed in the **Complex** method.

Current Control (Analog Dimming)

- Affects the panel relatively less and performs dimming.
- The minimum voltage is required so that even partial lighting is not available at the minimum brightness.
- Low Dimming Ratio (About 2 : 1)
- Loss of efficiency in dimming status because of the condition of Inverter which is optimized to the maximum brightness.

PWM Control (Burst Dimming)

- Dimming by flickering the lamp with the frequency about 300 Hz ~ 1kHz
- Turning periodically the high voltage on and off can cause the Ground instability of the Panel part and the water fall comes from the noise
- In the lamp lighting condition, it always activate in the maximum brightness. Therefore, the efficiency is high and the problem of partial lighting in the minimum brightness is improved- High Dimming Ratio (About 5:1)

Complex Control - Methods in Mendel

- In the initial step of the dimming, controls the water fall appearance with

3. Disassembly and Reassembly

Note : 1.Turn off the power of the monitor before disassembly.

2.Disassemble the product only with the supplied jig but not any other metal instruments.

3.Follow the directions below and carefully disassemble.

4.The jig for disassembling the rear cover : BH81- 00001A



1.Place the monitor on a cushioned table.

And remove the stand.

2. Remove the rear cover using jig.

3. Pushing (1) and lift (2) using jig or drive.

3. Disassembly and Reassembly

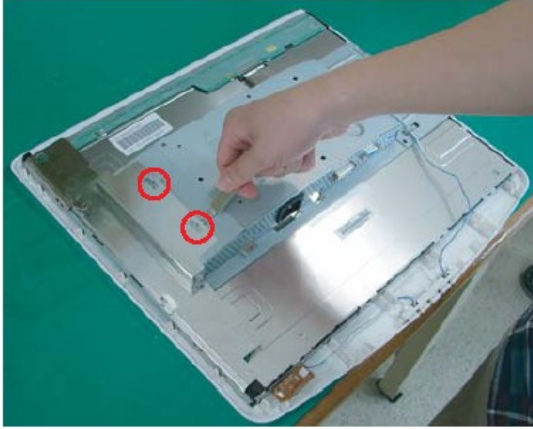

3. Remove the attached shield on the left by using the jig.

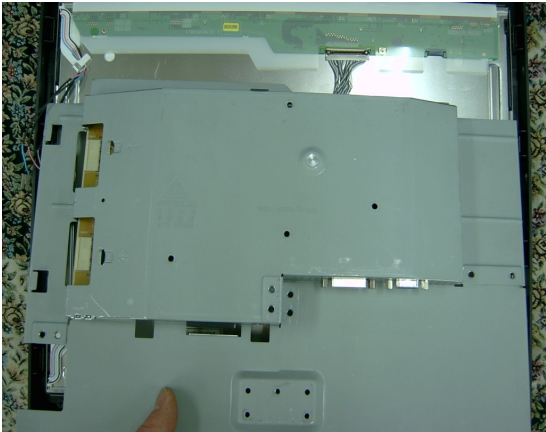

4. Carefully lift up the Ass'y with one hand and pull the LVDS HARNESS to detach.

3. Disassembly and Reassembly

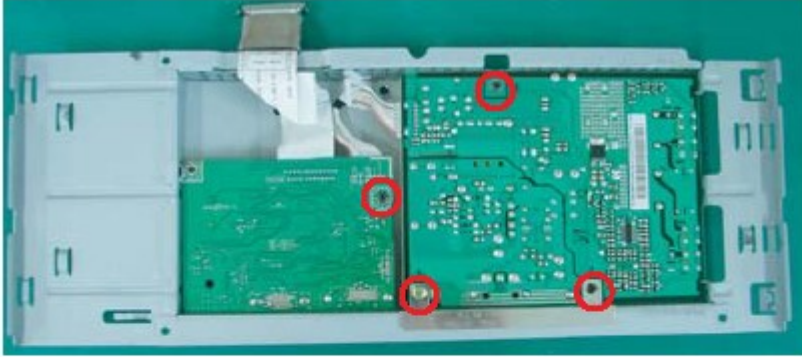

4. Remove the screws as the figures and detach the mainboard and the IP board from the panel.



5. Remove the Bracket Support

3. Disassembly and Reassembly

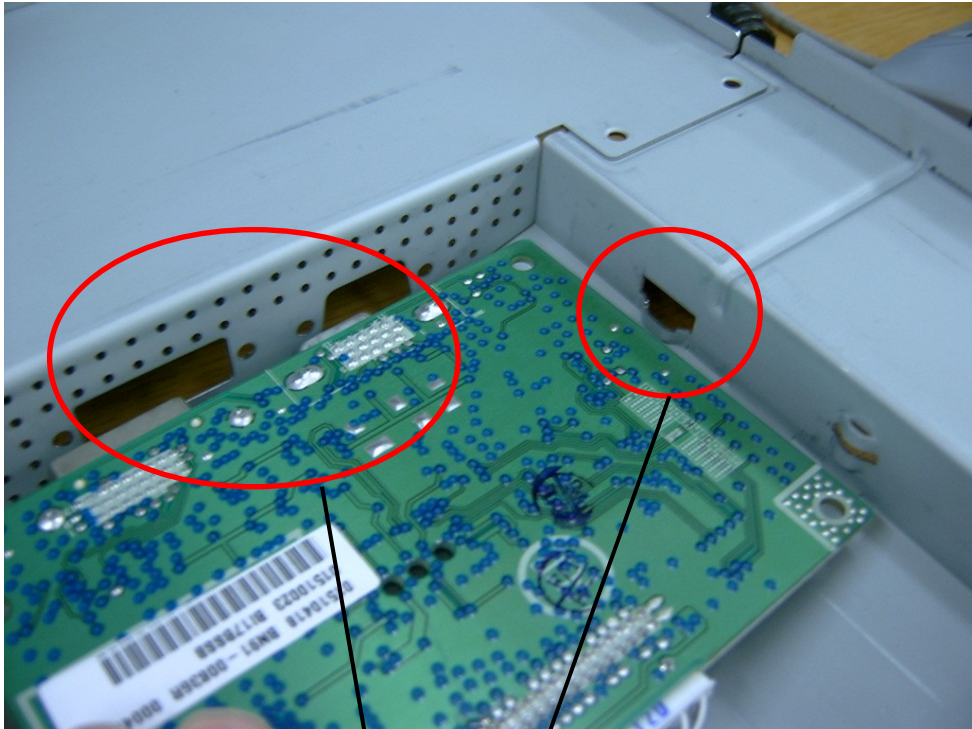

Fit to the holes to assemble.

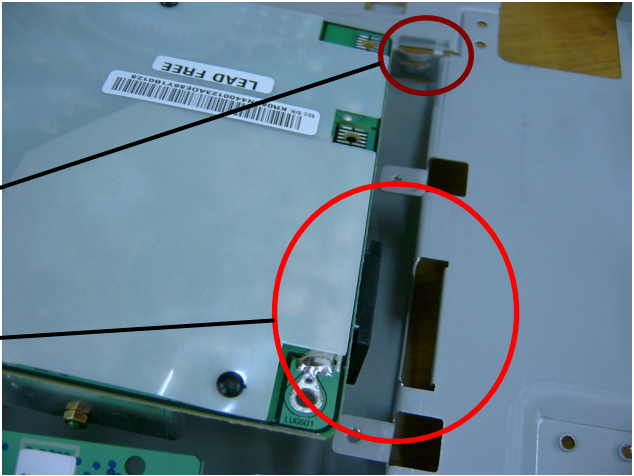

3. Disassembly and Reassembly

17"

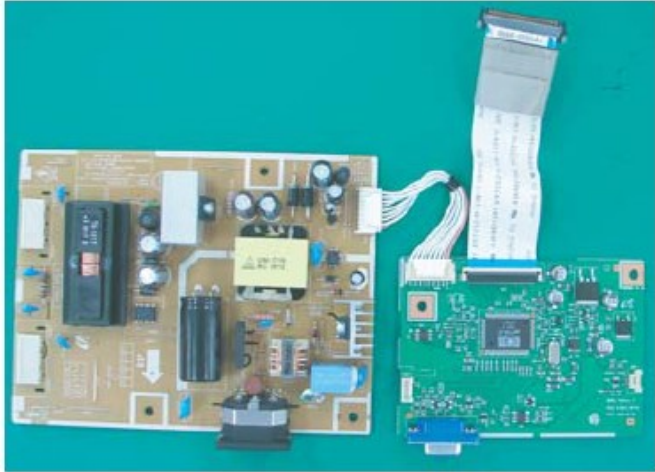

19"



3. Assembly stand

*. Stand assembly

- . This Model's stand is assembled by customer. (The an operating manual is attached in Box.)

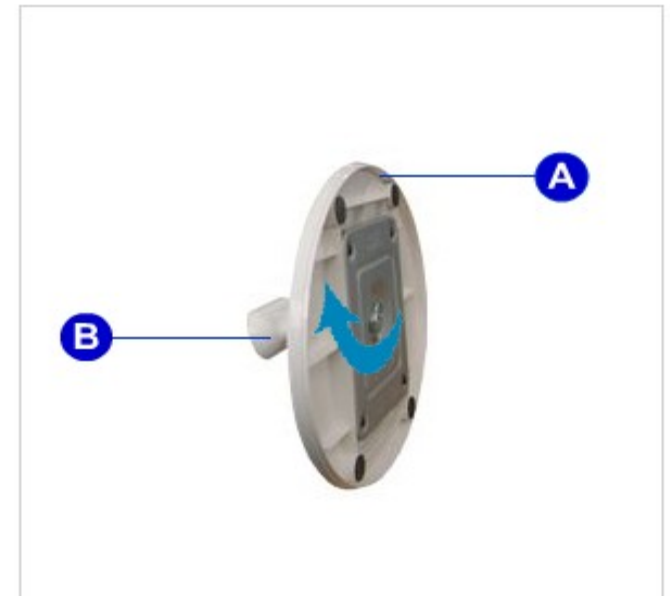

1. 1 and 2 put together . And connect A and B.
2. Lock nut of A

3. Assembly stand



1. Place the stand on a flat table forwarding the arrow direction.

3. Assembly stand



2. Tilt the monitor about 10~15 degree.

3. Assembly stand

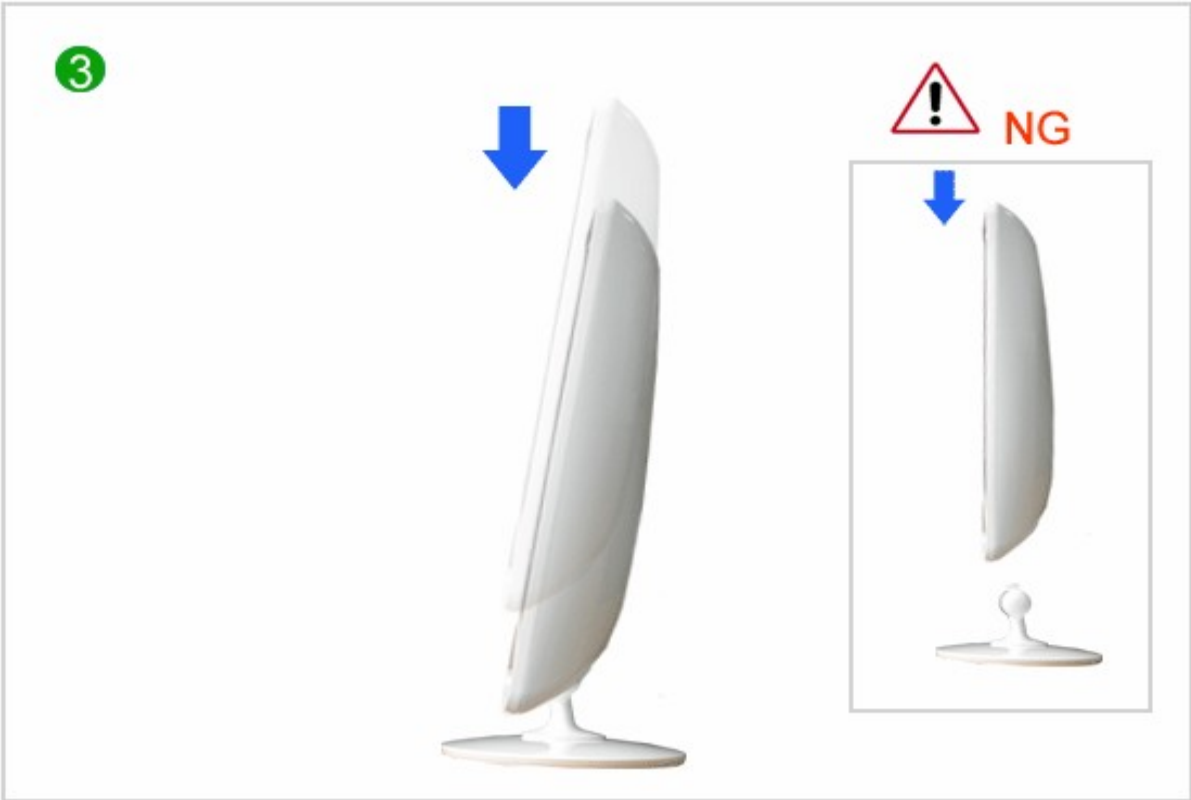

3. Grab the monitor and Push with 5kg strength .

3. Assembly stand

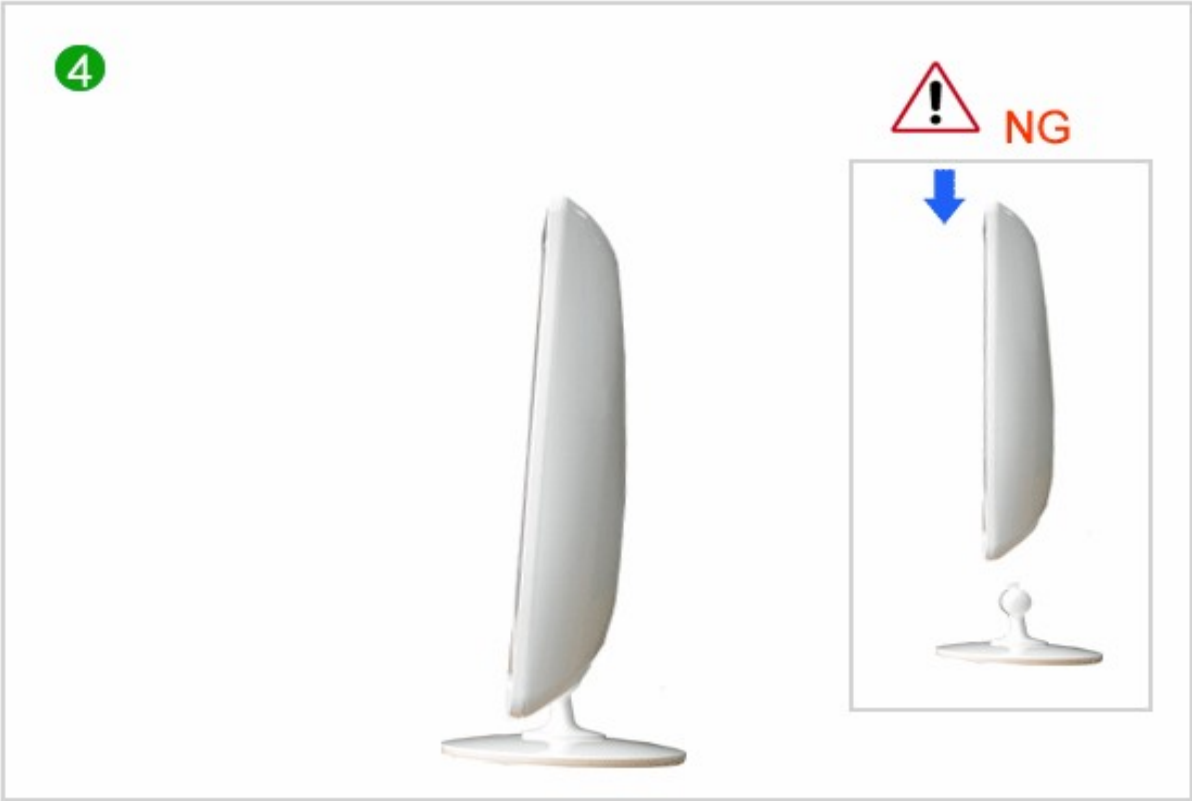

3. Check the monitor moving a monitor

4. Diagnosis and Adjustments (Troubleshooting)

❖ Check before Repair

- **Power and Cable Connection Check**
 - . Power Cable and Signal Cable connection check
 - . Function Key operation check
- **Check and manage before repair**
 - . Resolution : 1024 x 768/60Hz
 - . Run Auto
 - . Return to the Factory Mode
 - => Press the Menu button, then press and hold Enter button for 5 seconds or longer to automatically return to the Factory Mode. Automatically returns the factory mode.
- **Other simple test**
 - . If the Lamp shortly lights up and then goes out, the Lamp of Inverter/Panel may have a problem.
 - . If the LED does not work, there may be problems in Inverter/Micom/Function Block.

4. Diagnosis and Adjustments (Troubleshooting)

- Notes:
1. Before troubleshooting, setup the PC's display as below.
 - Resolution: 1024 x 768
 - H-frequency: 61 kHz
 - V-frequency: 75 Hz
 2. If no picture appears, make sure the power cord is correctly connected.
 3. Check the following circuits.
 - No raster appears: Function PBA, Main PBA, I/P PBA
 - 5V develop but no screen: Main PBA
 - 5V does not develop: I/P PBA
 4. If you push and hold the " (Enter/Source)" button for more than 5 seconds, the monitor automatically returns to the factory preset.

4. Diagnosis and Adjustments (Troubleshooting)

No Power

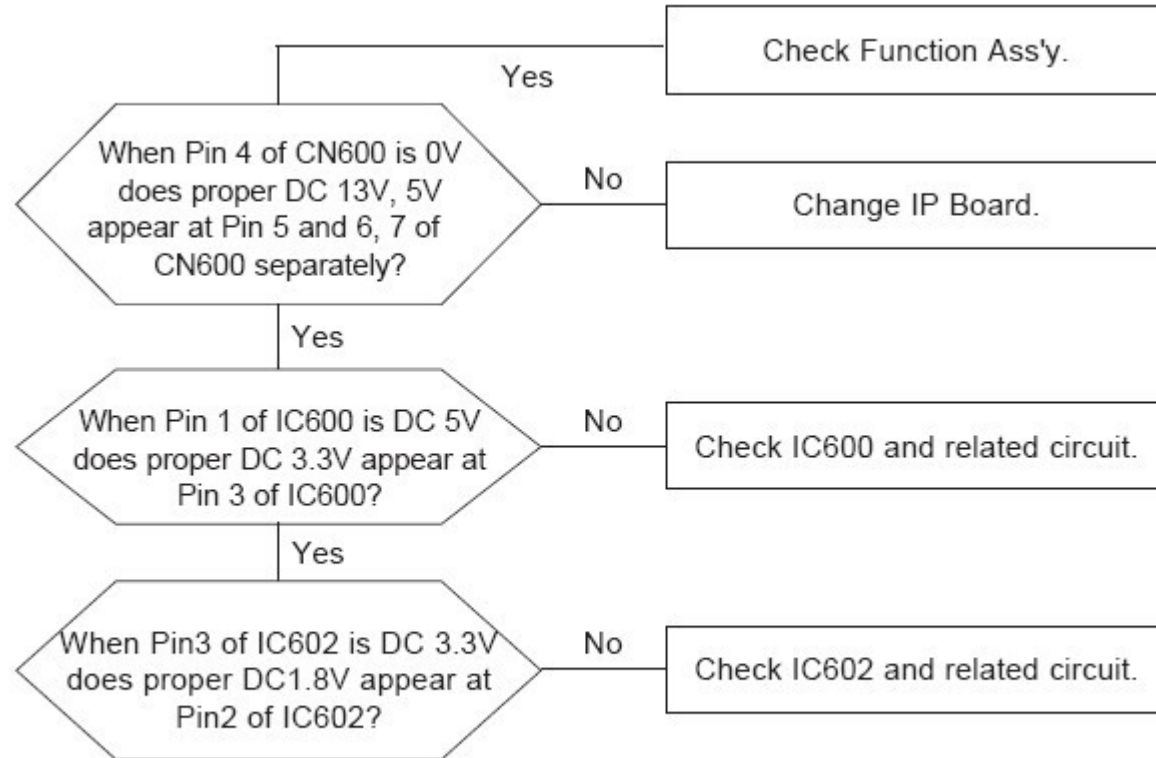

* All locations of this page includes Main PBA.

4. Diagnosis and Adjustments (Troubleshooting)

No Video (Analog)

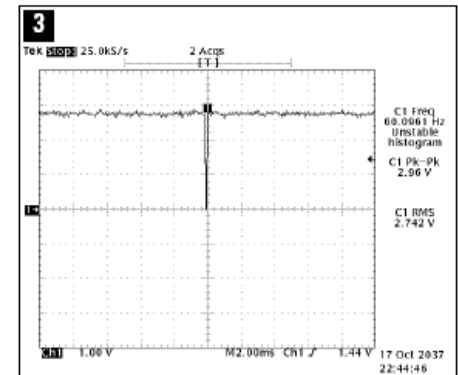
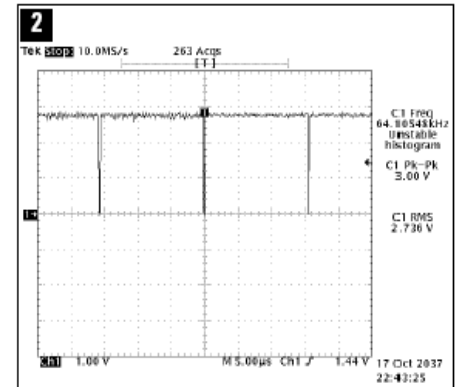
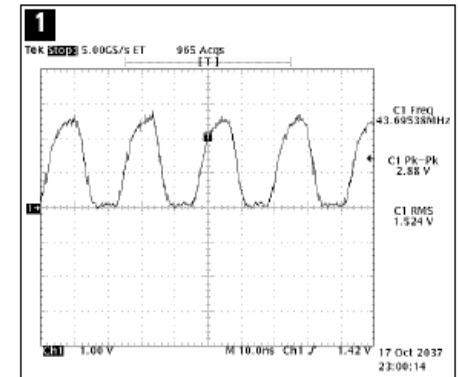
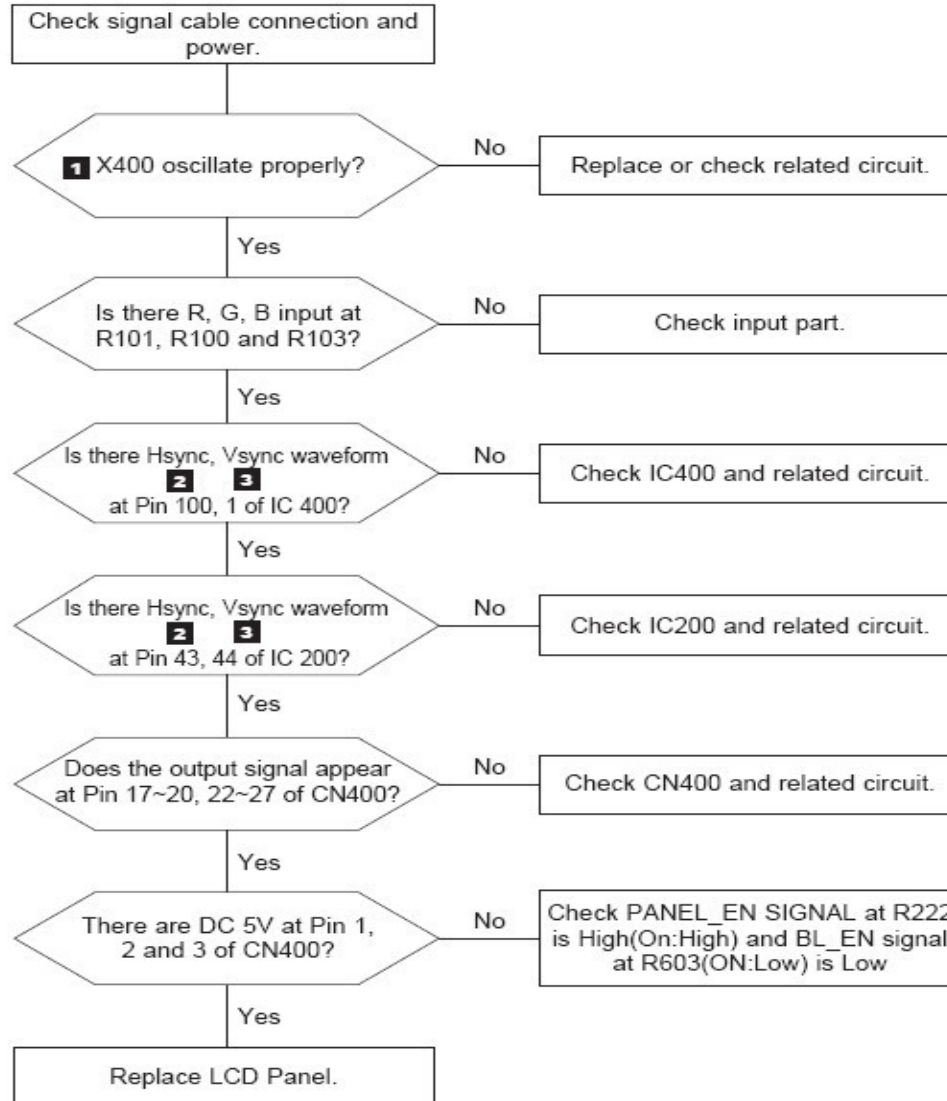

4. Diagnosis and Adjustments (Troubleshooting)

No Video (Digital)

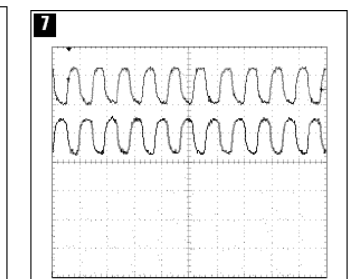
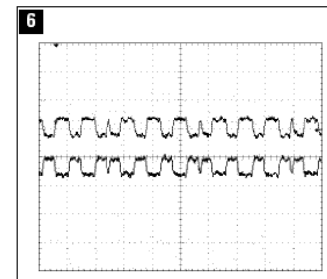
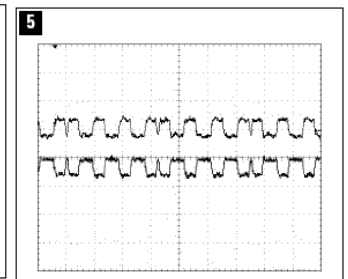
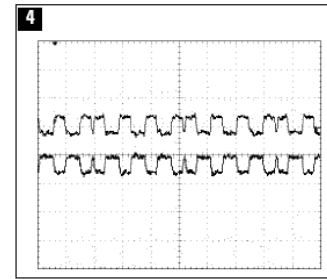
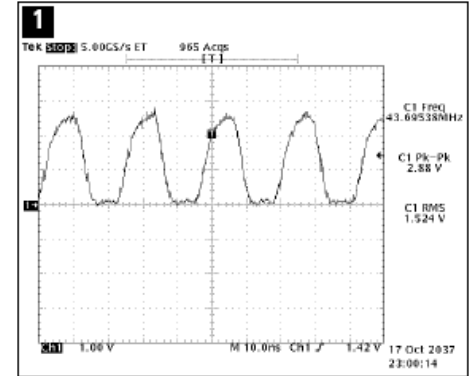
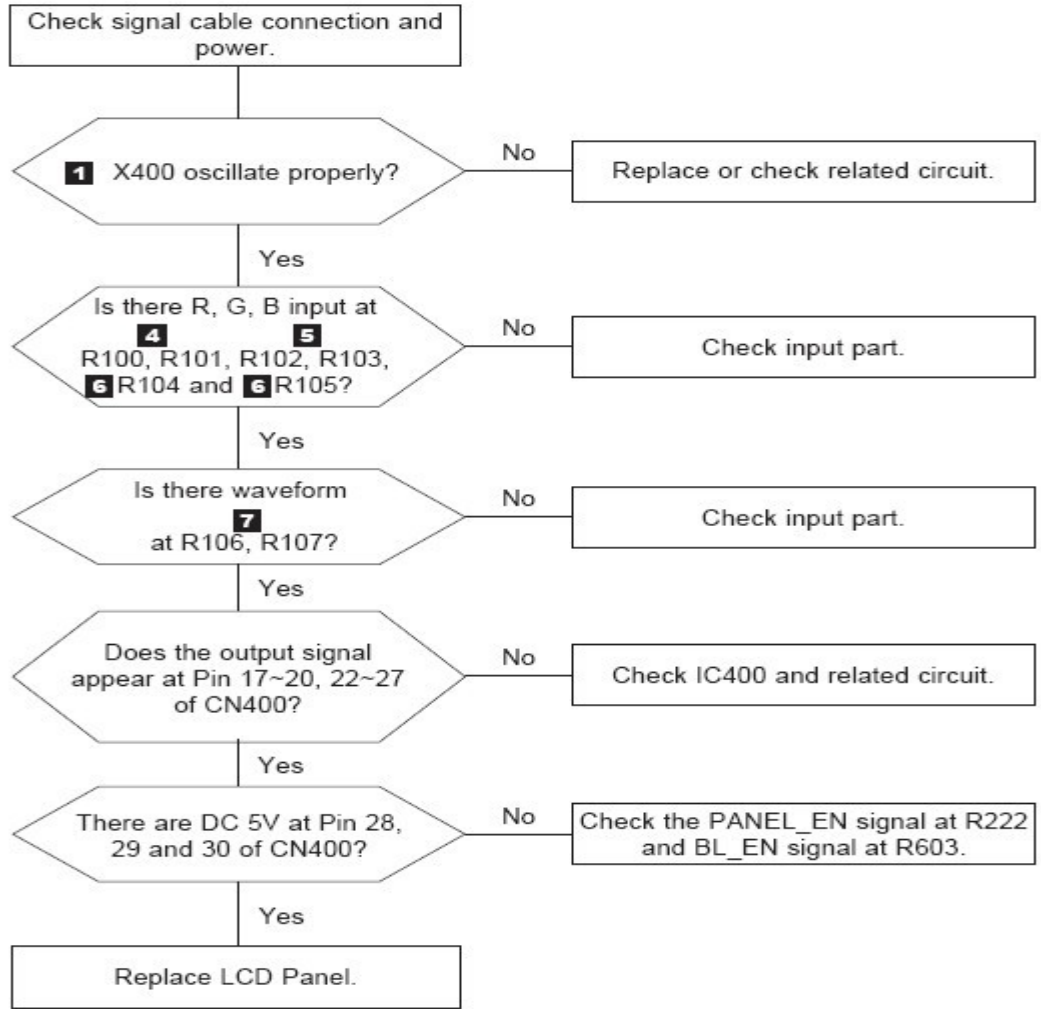

* All locations of this page includes Main PBA.

4. Diagnosis and Adjustments (DDC)

After exchange the Main Board, We use the DDC control JIG and must complete downloading.
For Connection, refer to below picture.

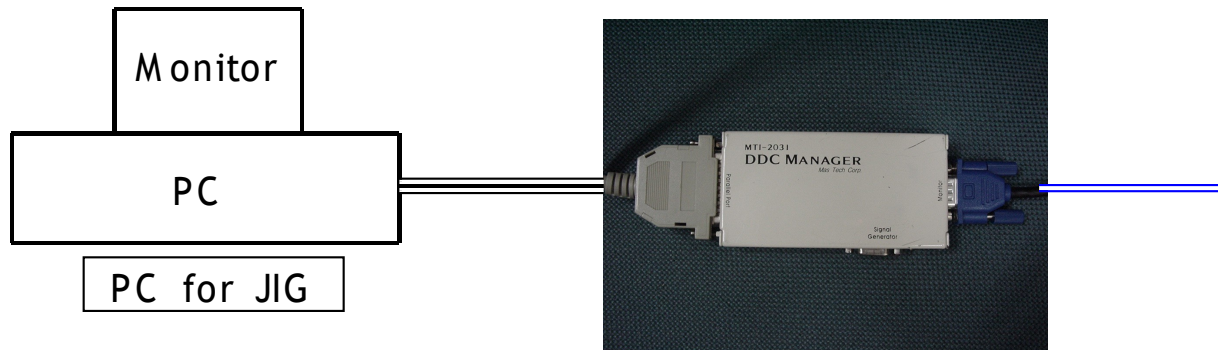

4. Diagnosis and Adjustments (DDC)

- 1) Use the DDC Manager MTI - 2050 and later version.
- 2) Run the program and select the DDC file name.

Program : WnDDC BY SAMSUNG ELEC. Co. [Ver: 4.65.12V] --- Modify :
20050425

DDC : 731B.ddc or 931B.ddc

- 3) Insert to the DDC Manager Port 1 (Analog) as the current Dual model, and input the DDC and check.
- 4) Insert the DDC Manager Port 2(Digital), and input the DDC and check.



DDC Program



DDC file

4. Diagnosis and Adjustments (DDC)

1: Open the file.

2: Select the Port 1.

3: Select the DDC file.
(731B/931B)

4: Click Next(OK) button.

4. Diagnosis and Adjustments (DDC)

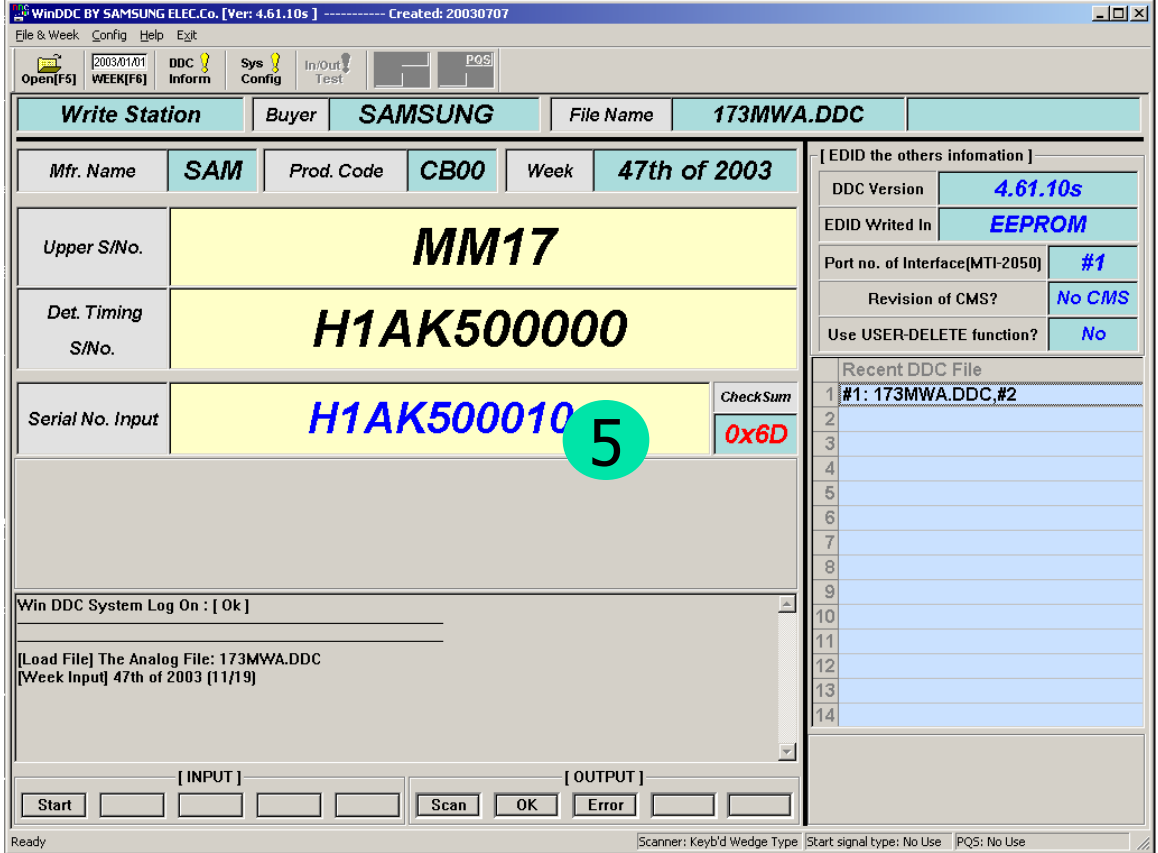

5: Enter the serial numbers and press the Enter Key.



Enter Analog and repeat 2 to 5 times when you enter Digital.

4. Diagnosis and Adjustments (Code)

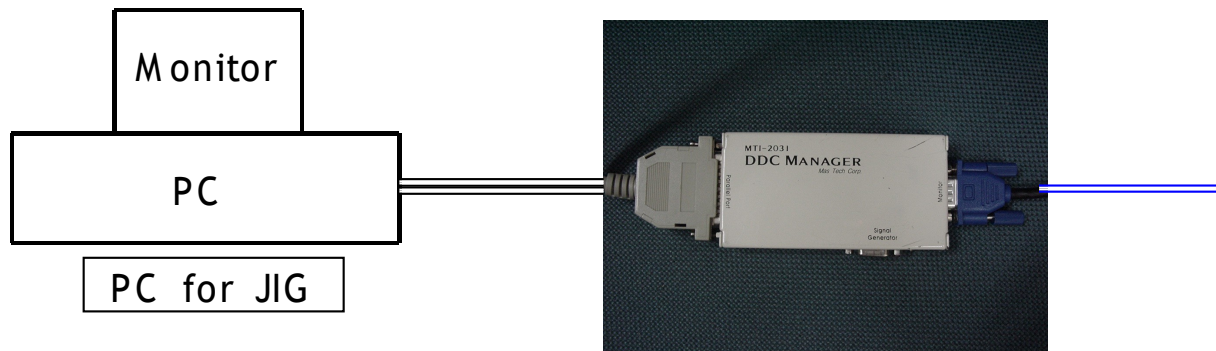
1. Use to update the AD Board Code.
2. Download the GProbe Program and the Hex compatible with the model through QA Department of the headquarter, then attach the Jig as shown in the diagram and input the data.
3. For Connection, refer to below picture.



4. Diagnosis and Adjustments (Code)

Order	Description	Example
1	DDC Manager Connection . Connect the DDC Manager to the PC or Monitor	<ul style="list-style-type: none"> . Parallel Port Connect the Parallel port of the PC to the DDC Manager. . Monitor Connect the D- Sub port of the LCD Monitor to the DDC Manager. . Signal Generator Connect the Signal Generator to the DDC Manager.
2	Install the GProbe program and unzip the Batch.zip file, then copy the unzipped Batch file to same directory which you installed GProbe.	<ul style="list-style-type: none"> . Run GProbe 5.2.0.2.exe. <div style="display: flex; justify-content: space-around; align-items: center;"> <div style="text-align: center;">  <p>GProbe.zip</p> </div> <div style="text-align: center;">  <p>Batch.zip</p> </div> </div>
3	GProbe Program Setting	<ul style="list-style-type: none"> . Refer to the next page and perform the Config Setting.
3	Change and store the Hex route under the batch file to where the code is stored.	<ul style="list-style-type: none"> . Open the batch file under the GProbe 5 folder and change the Hex route in the middle.
4	Download the Hex. <div style="text-align: center; margin-top: 10px;">  <p>MCU Code</p> </div>	<ul style="list-style-type: none"> . Run the Batch. Batch “batch file name.txt” and click Execute. If the route of the Batch File is not under the GProbe5, the Full route should be written.

4. Diagnosis and Adjustments (Code)

Config Setting

The screenshot shows the Genesis GProbe 5 software interface. The main window displays a command prompt with the following text:

```
// fastFlashWrite D:\W1ISP_Serial\W26xx_proj.hex  
//fastFlashWrite C:\WProj\WHIQ\WAPP-52xx1.4RELA\W52xx-app\Wdebug\Wobj\W56xx  
fastFlashWrite D:\Wmendel\W_Mendel\W56xx_proj.hex  
  
// to reset the monitor after programming the flash using DDC2BI ONLY:  
// Un-comment the following three lines (PLEASE - FOR DDC2BI PORT SELECTED C  
//0x8000=1
```

Two 'Connection Settings' dialog boxes are overlaid on the main window. The left dialog box is titled 'Connection Settings' and has the 'Pin Assignments' tab selected. It shows the following settings:

- Connection: Pin Assignments
- Serial: USB
- Parallel: Delays and Buffer Size
- SCL Signal:
 - Input Pin: 15 (active high)
 - Output Pin: 5 (active low)
- SDA_Signal:
 - Input Pin: 11 (active high)
 - Output Pin: 9 (active low)
- Scheme: (empty)

The right dialog box is also titled 'Connection Settings' and has the 'Connection' tab selected. It shows the following settings:

- Pin Assignments: Connection
- USB: Serial
- Delays and Buffer Size: Parallel
- Devices:
 - Device: Parallel
- Protocols:
 - Protocol: DDC2Bi3
- Scheme: (empty)

Buttons for '확인' (OK) and '취소' (Cancel) are visible at the bottom of both dialog boxes.

4. Diagnosis and Adjustments (Code)

Make change for the Batch File

The screenshot shows the Genesis GProbe 5 software interface. The main window is titled "Genesis GProbe 5 - [Batch]". It features a menu bar (File, Edit, View, Register, Terminal, Commands, Options, Window, Help) and a toolbar with various icons. On the left, there is a "Registers" panel with a "Select Chip" dropdown set to "gm5621" and a search field. Below this is a 7-bit LED display showing "00000000" and a table of registers:

Description	Address	Value	Size
HOST_CONTROL	8000	0	8
PRODUCT_ID	8001	0	8
PRODUCT_REV	8002	0	8
CLOCK_CONFIG	8003	0	8

The main area contains a batch file editor with the following code:

```
// fastFlashWrite D:\W1ISP_Serial\W26xx_proj.hex  
//fastFlashWrite C:\WProj\WHIQ\WAPP-52xx1.4RELA\W52xx-app\Wdebug\Wobj\W56xx  
fastFlashWrite D:\W Mendel\WCode\W56xx_proj.hex  
  
// to reset the monitor after programming the flash using DDC2BI ONLY:  
// Un-comment the following three lines (PLEASE - FOR DDC2BI PORT SELECTED C  
//0x8000=1  
//0x8003=0  
//0x8027=1  
  
// batch "C:\WProgram Files\Genesis Microchip\WGProbe 5\Wbatch.txt"
```

At the bottom, there is a command line area with "batch batch.txt" entered and an "Execute" button highlighted in red. The status bar at the bottom left shows "Ready" and the bottom right shows "NUM".

4. Diagnosis and Adjustments (Code)

1

The screenshot shows the Genesis GProbe 5 software interface. The top window displays the Register window with a table of registers for chip gm5766. The middle window shows a code editor with a batch file script. The bottom window shows the Batch execution window with the output of the script.

Description	Address	Value	Size
HOST_CONTROL	8000	0	8
PRODUCT_ID	8001	0	8
PRODUCT_REV	8002	0	8
CLOCK_CONFIG	8003	0	8
OCM_TCLK_DIV	8004	0	8
BYPASS	8006	0	8
IRQ_CONFIG	800B	0	8
IFM_OCMMASK	800C	0	8
INPUT_OCMMA...	800D	0	8
MISC_OCMMASK	800E	0	8
SYSTEM_STAT...	800F	FFFFFFFF	8
IFM_STATUS	8010	0	8

```
delay 100
////Enable both setDelay before and after flashErase if batch file failed
//SetDelay has the same capability which set short and long delay timeout in gProbe connection cor
//syntax: setDelay shortTimeout LongTimeout
SetDelay 1000 9000

FlashErase

SetDelay 1000 3000

// Change this line to point to a file in a different location, if needed
// fastFlashWrite D:\W1ISP_Serial\W26xx_proj.hex
//fastFlashWrite C:\WProj\W1Q\WAPP-52xx1.4\RELA\W52xx-app\Wde...#56xx_proj.hex
//fastFlashWrite D:\Wmendl\Wcode\WPhoenix.hex
fastFlashWrite D:\Wcode\W20051227_Phoenix_19_V8002_9012.hex
// to reset the monitor after programming the flash using DDC2BI ONLY:
// Un-comment the following three lines (PLEASE - FOR DDC2BI PORT SELECTED ONLY)
//0x8000=1
//0x8003=0
//0x8027=1
```

batch mendel.txt

```
RAMWrite: Command Successful.
Run: Command Successful.
Delay: Command Successful.
RAMWrite: Command Successful.
Run: Command Successful.
Delay: Command Successful.
SetDelay: Command Successful.
Erasing FLASH... Done.
SetDelay: Command Successful.
Writing FLASH... Done.
Execution time: 17.38s
Batch: Command Successful.
```

- 1: Open the file
- 2: Change the file name and route to the Hex which you will download.
- 3: Batch batchfilename.txt and select Execute.
- 4: Turn off the Hard Power until the LED successfully turned off.

- ** If there is an error when you batch :
1. Turn the Hard Power Off
 2. Enter "forcesa" on the command window.
 3. Turn the Hard Power On
 4. Batch again

4. Diagnosis and Adjustments (MCU Code)

Check MCU Code Version

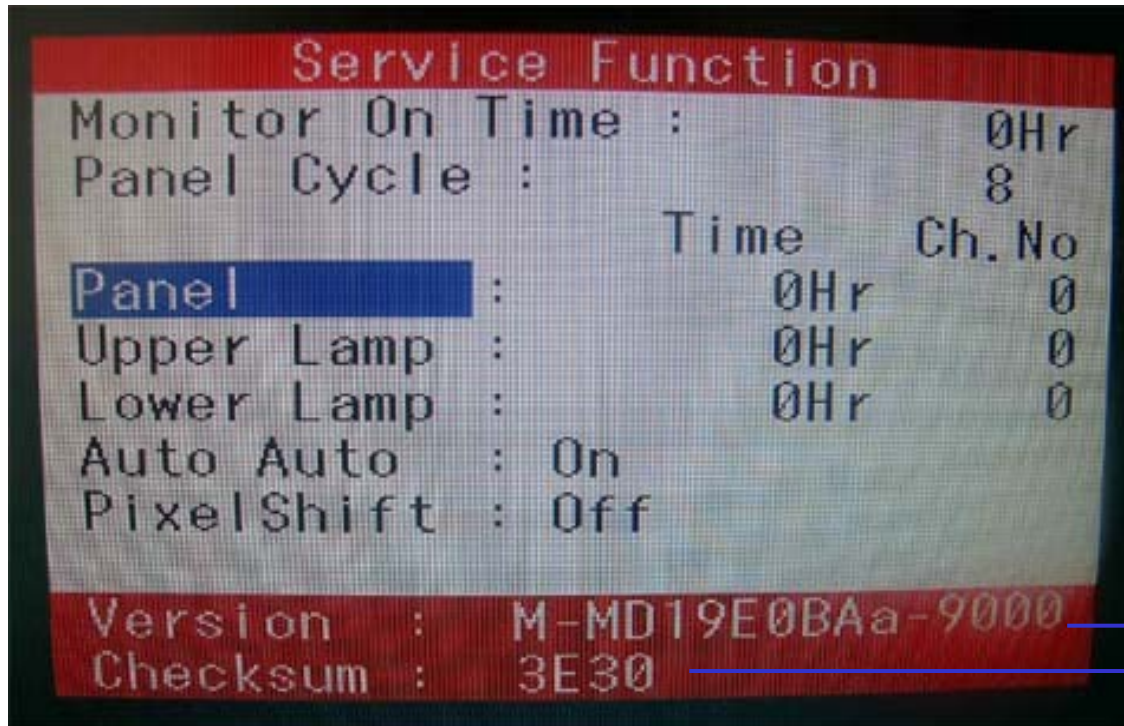

Entering SVC Mode,
check MCU Code Version and
CheckSum.

About how to Entering SVC,
refer to 58P

MCU Version

CheckSum

4. Diagnosis and Adjustments (Auto Color)

Auto Color

- PC analog (1024X768@60):Used Equipment : MSPG- 3240L

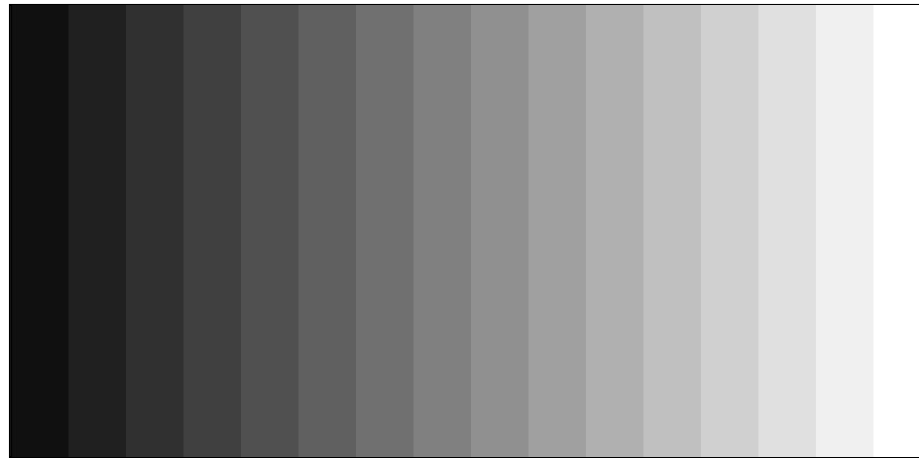

PC Analog Adjustment Pattern(16 GRAY)

- Press the Menu key for about 5 seconds on Language English of the OSD.

4. Diagnosis and Adjustments (Self Test)

- ❖ The Function and Purpose of Self Test
 - This function is added to easily check if your monitor is functioning properly and minimize the claim calls from users without a defect.
- ❖ How to perform Self Test
 - Check if it is normal while you press the Menu key in

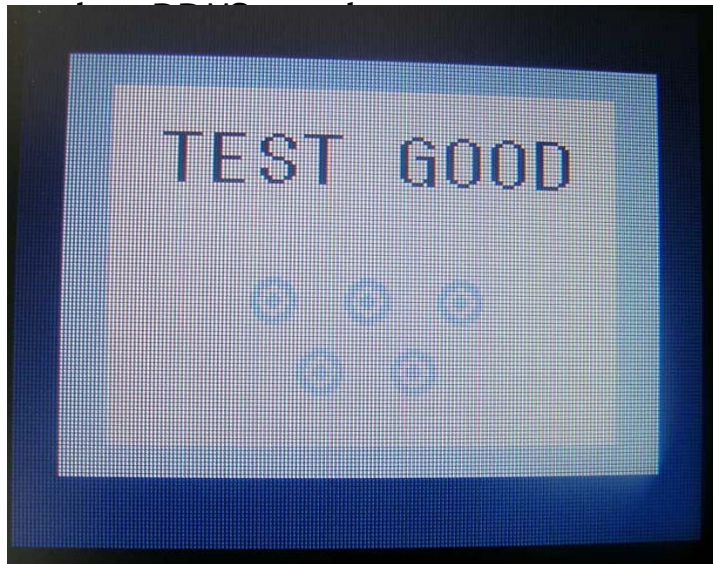

No Image displayed	Check if the message is output.
Misfocus	Check how vague the phrase "TEST GOOD" looks.
Image Trembling	Check how badly the message box shakes.

4. Diagnosis and Adjustments

❖ Entering Service Mode

- Adjust the Brightness and Contrast levels to 0.
- Press and hold the Enter key for about 5 seconds.
- The SVC Function OSD appears.
- Turn the power off to exit the SVC Function.

❖ Safe Mode

➤ When the input signal supported by the product is higher than the supported frequency, this mode allows the users the time (one min.) to change the Video Card Setting so they can change the setting to the Recommend Mode.

For 17" : **UXGA/60Hz and 75Hz** are supported and the **Down Scaling** is performed for one minute to display. But it is switched to **Sync Out of Range** when it's higher than **85Hz** to protect the panel from damage.

4. Diagnosis and Adjustments (Service mode)

1. The Value for brightness and contrast should be changed to zero.
2. Within 5 seconds, press the Enter key.
3. Service function OSD will be displayed.

* If you want to disable the service function OSD, you will have to power off

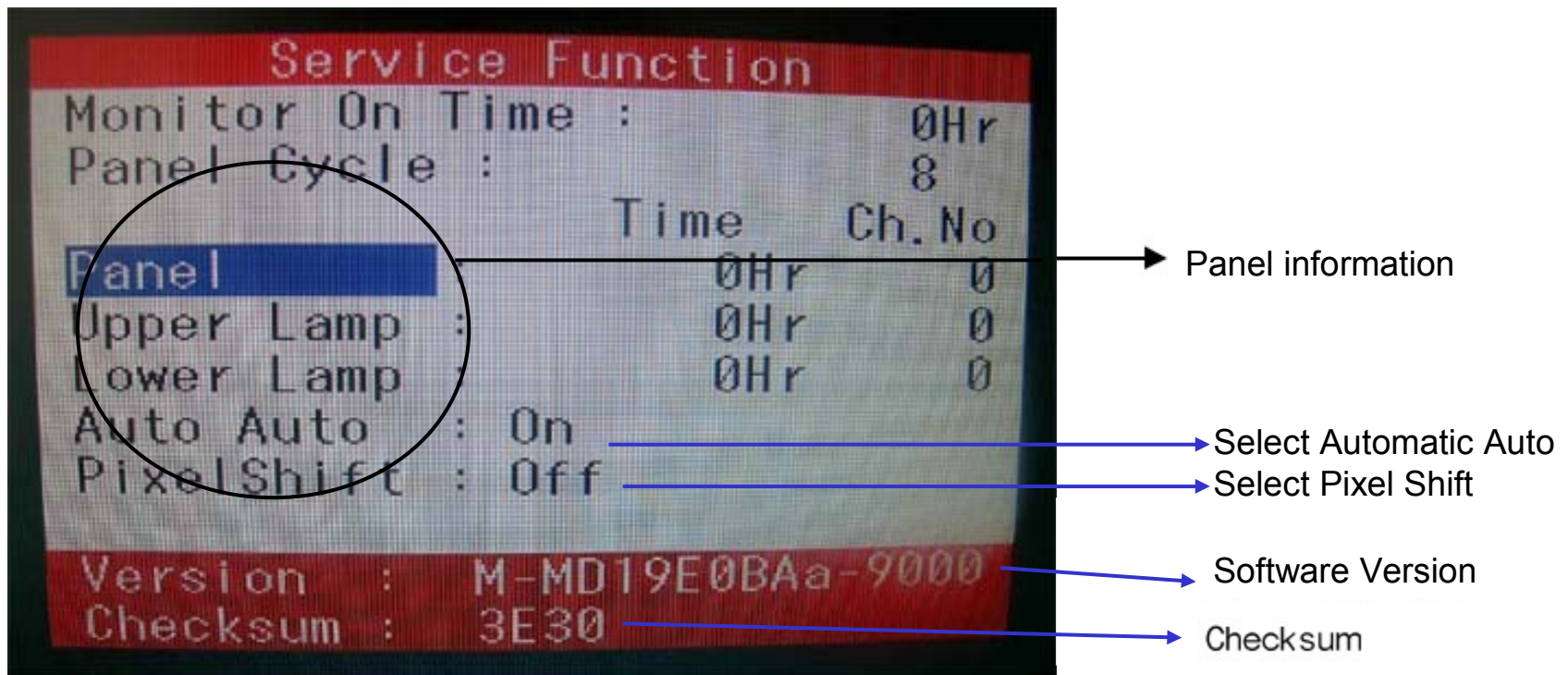

The service function OSD is based on grid of 29 columns x 12 rows.

The service function OSD consists of Panel information, software version and Checksum

4. Diagnosis and Adjustments (Service mode)

With the panel selected on OSD, whenever you press the right key, the base color will change to blue from "Panel" to "Upper Lamp", "Lower Lamp"

The image shows three sequential screenshots of the Samsung OSD Service Function menu, illustrating the navigation process. Blue circles and arrows highlight the changes between screens.

Screenshot 1 (Left): The menu is titled "Service Function". It shows "Monitor On Time : 0Hr" and "Panel Cycle : 8". The "Panel" option is highlighted in blue. Below it are "Upper Lamp", "Lower Lamp", "Auto Auto", and "PixelShift". At the bottom, "Version :" and "Checksum :" are visible.

Screenshot 2 (Middle): The menu is the same, but "Upper Lamp" is now highlighted in blue. The "Panel" option is no longer highlighted.

Screenshot 3 (Right): The menu is the same, but "Lower Lamp" is now highlighted in blue. The "Upper Lamp" option is no longer highlighted. This screen also displays a table of settings:

	Time	Ch.No
Panel	0Hr	0
Upper Lamp	0Hr	0
Lower Lamp	0Hr	0
Auto Auto	On	
PixelShift	Off	

At the bottom of this screen, "Version : M-MD19E0BAa-9000" and "Checksum : 3E30" are displayed.

4. Diagnosis and Adjustments (Service mode)

-The case of Panel Change

After changing the panel, press the menu key within 5 seconds.

Then, panel ch. no increase on step and the panel time information is reset to zero.

Simultaneously, other information is reset to zero (Upper/ Lower Lamp, Panel Cycle).

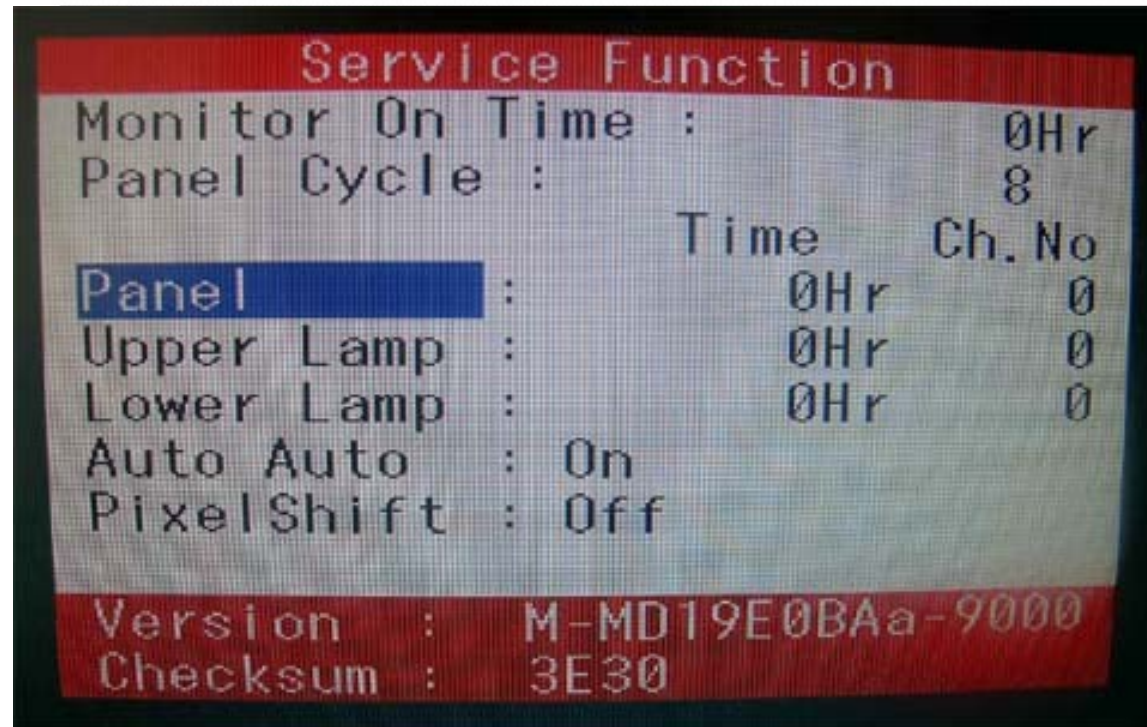

4. Diagnosis and Adjustments (Service mode)

-The case of Upper Lamp or Lower Lamp Change

After changing the Upper Lamp or Lower Lamp,

1. Select the Upper Lamp or Lower Lamp.
2. Press the Menu key within an 5 seconds.

Then, Ch.No and time will be reset to zero (selected item only)

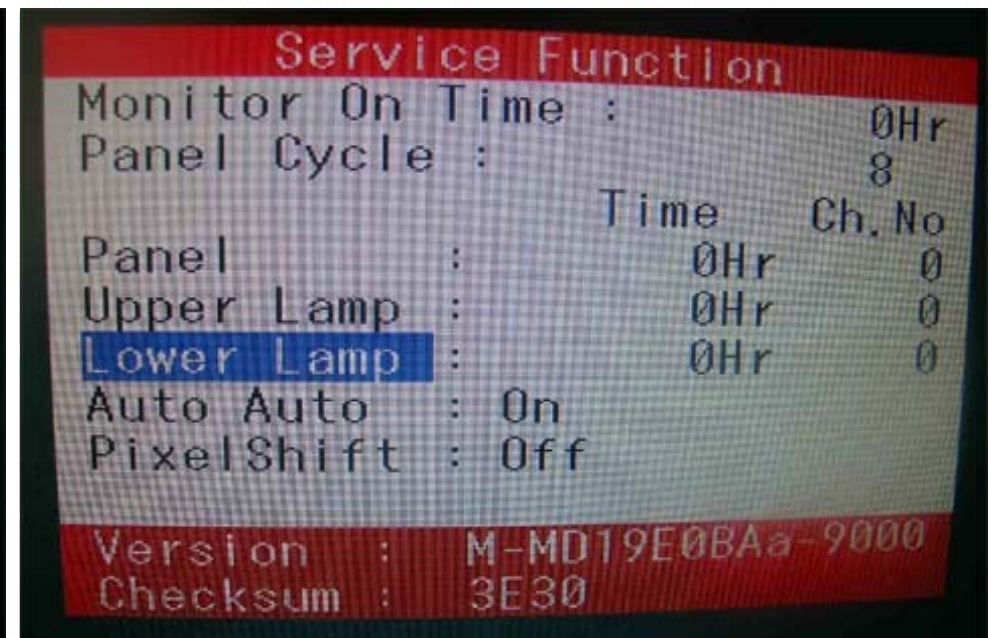

4. Diagnosis and Adjustments.

After exchange the Main PBA, confirm below items

- PC color status check (Auto Color)
- EDID Input (Analog and Digital)
- **Check the MCU Code**
(After change MCU Code, Do Auto color)
- Factory Reset